

Ray215

VHF Radio

Owner's Handbook



Raymarine
ON BOARD

RAY215
Modular
VHF Radio
Owner's
Handbook

Document number: R49013_2
Date: March 2002

Purpose

This handbook contains very important information on the installation, operation, and maintenance of your new equipment. To get the best results in operation and performance, please take the time to read this handbook thoroughly.

RAY215

Raymarine radios comply with the Federal Communications Commission (FCC) and Industry Canada requirements that regulate marine VHF radio usage for the US and Canada, respectively.

Marine VHF radio users in the US must comply with all applicable FCC rules and regulations, which are described in Section 6. This information was current at the time this handbook was printed. Up-to-date information, including licensing requirements, can be obtained on the FCC website at:

www.fcc.gov/wtb/marine

Official FCC forms can be obtained on the FCC website at:

www.fcc.gov/formpage.html

FCC NOTICE

This device complies with Parts 15 and 80 of the FCC Rules. Operation is subject to the conditions that this device does not cause harmful interference. Changes or modifications to this equipment not expressly approved in writing by Raymarine, Incorporated could violate compliance with FCC rules and void the operator's authority to operate the equipment.

FCC Licensing

An FCC Ship Radio Station License, Call Sign, and Operator License are not required for most recreational vessels travelling in US waters. For specifics on FCC licensing requirements, see Section 6 of this handbook.

Maritime Mobile Service Identity (MMSI)

The RAY215 includes equipment for Digital Selective Calling (DSC). A nine-digit Maritime Mobile Service Identity (MMSI) number is required to operate the DSC equipment. You can request an MMSI number from the FCC when you apply for a Station License. If your vessel does not require a license, you may obtain an MMSI by contacting either BoatUS (www.boatus.com) or MariTEL (www.maritelusa.com). Once obtained, you can program the MMSI number into your RAY215 as described in this handbook.

INDUSTRY CANADA

You do not need a license to operate this radio within sovereign waters of Canada or the US. You will need a license to operate this radio outside of Canada or the US. To obtain Industry Canada licensing information, contact the nearest field or regional office, or write:

Industry Canada
Radio Regulatory Branch
Attention: DOSP
300 Slater Street
Ottawa, Ontario
Canada, KIA OC8

The following information about the radio is required to complete the license application:

Industry Canada Certification Number	4069823229AV
FCC Type Number	PJ5RAY215
FCC Type Accepted	Parts 15 and 80
Output Power	1 watt (low) & 25 watts (high)
Modulation	16FE (FM)
Frequency Range	156.025-157.425

SAFETY NOTICE

This device is only an aid to navigation. Its performance can be affected by many factors including equipment failure or defects, environmental conditions, and improper handling or use. It is the user's responsibility to exercise common prudence and navigational judgement, and this device should not be relied upon as a substitute for such prudence and judgement. Your Raymarine VHF radio generates and radiates radio frequency (RF) electromagnetic energy (EME). This equipment must be installed and operated in accordance with the instructions contained in this handbook. Failure to do so can result in personal injury and/or product malfunction.

Antenna Mounting and EME Exposure

For optimal radio performance and minimal human exposure to radio frequency electromagnetic energy, make sure the antenna is:

- connected to the radio before transmitting
- properly mounted
- located where it will be away from people
- located at least three feet (91cm) from the RAY215 and the microphone/handset

Safe Compass Difference

Safe Compass Distance is 1 meter for a common mechanical compass; other compass types may require greater distances. To be sure, you should locate the radio as far as possible from the compass. Test your compass to verify proper operation while the radio is also operating.

Adjustments or Repair

Adjustments require specialized service procedures and tools only available to qualified service technicians – there are no user serviceable parts or adjustments. The operator should never remove the cover or attempt to service the equipment.

Raymarine products are supported by a network of Authorized Service Representatives. For product information you may contact the following regional centers:

United States	Raymarine, Inc. 22 Cotton Road, Unit D Nashua, NH 03063-4219 USA Telephone: 603-881-5200 800-539-5539 Fax: 603-864-4756
Europe	Raymarine Ltd Anchorage Park Portsmouth, Hampshire England PO3 5TD Telephone: +44 (0) 23 9269 3611 Fax: +44 (0) 23 9269 4642

© Raymarine, Inc. 2001

Table of Contents

Section 1 General Description

1.1	Introduction	1-1
1.2	Equipment Features	1-1
1.3	Microphone / Handset Options	1-2

Section 2 Installation

2.1	Unpacking and Inspection	2-1
2.2	Equipment Supplied	2-1
2.2.1	Optional Accessories	2-1
2.3	Planning the Installation	2-2
2.3.1	Typical Mounting Methods	2-2
2.3.2	Flush Mounting	2-3
2.4	Electrical Connections	2-6
2.4.1	DC Power and External Speaker Connections	2-6
2.4.2	External Speaker Connections	2-7
2.4.3	NMEA Data	2-8
2.4.4	Antenna Connections	2-8
2.4.5	Antenna Mounting Suggestions	2-9
2.4.6	Grounding	2-9

Section 3 Operation with Standard Fist Microphone

3.1	Introduction	3-1
3.1.1	Microphone/Full Function Handset Priority	3-1
3.1.2	Microphone/Handset Connections	3-2
3.2	Control and LCD Display	3-3
3.2.1	Controls	3-3
3.2.2	LCD Display	3-6
3.3	Operating Procedures	3-8
3.3.1	Turning the Power On	3-8
3.3.2	Setting the Squelch	3-8
3.3.3	Setting the Volume	3-8
3.3.4	Setting the Power Output	3-8
3.3.5	Setting the Channel	3-8
3.3.6	Setting the Frequency Mode	3-9
3.3.7	Transmitting	3-9
3.3.8	Selecting a Weather Channel	3-9
3.3.9	Priority Channel	3-10
3.3.10	Desensitized Reception	3-10
3.3.11	Channel Memory	3-10

3.3.12	Resetting Factory Defaults	3-10
3.3.13	Scan Modes	3-11
3.3.14	Monitor Mode	3-12
3.3.15	LCD Backlight Function	3-12
3.3.16	NMEA Operation	3-13
3.3.17	Digital Selective Calling (DSC).....	3-14
3.3.17.1	MMSI Number Setup	3-15
3.3.17.2	Individual Ship's Call	3-16
3.3.17.3	All Ships Call	3-24
3.3.17.4	Group Call	3-25
3.3.17.5	Distress Call	3-26
3.3.17.6	Distress Relay Call	3-28

Section 4 Operation with Optional Full Function Handset

4.1	Introduction	4-1
4.1.1	Microphone/Full Function Handset Priority	4-1
4.1.2	Microphone/Handset Connections	4-2
4.2	Control and LCD Display	4-3
4.2.1	Controls	4-3
4.2.2	LCD Display	4-7
4.3	Radio Functions	4-9
4.4	Operating Procedures	4-10
4.4.1	Setting the Volume	4-10
4.4.2	Setting the Squelch	4-10
4.4.3	Using the Function Key	4-11
4.4.4	Setting the Frequency Mode	4-11
4.4.5	Receiving on the Weather Channels	4-12
4.4.6	Selecting the Channel	4-12
4.4.7	Priority Channel	4-13
4.4.8	Channel Memory	4-13
4.4.9	Setting the Transmission Power Output	4-14
4.4.10	Desensitized Reception (Local Mode)	4-14
4.4.11	LCD Backlight Function	4-14
4.4.12	Intercom Mode	4-14
4.4.13	Scan Mode	4-16
4.4.14	Monitor Mode	4-17
4.4.15	NMEA Operation	4-18
4.4.16	Digital Selective Calling (DSC)	4-19
4.4.16.1	Individual Ship Call (Ship-to-Ship)	4-20
4.4.16.2	Individual Shore Call (Ship-to-Shore)	4-23
4.4.16.3	Receiving Individual Ship's Call	4-25
4.4.16.4	Transmitting a Group Call	4-26

4.4.16.5	Receiving Group Call	4-28
4.4.16.6	Transmitting All Ships Call	4-29
4.4.16.7	Receiving All Ships Call	4-30
4.4.16.8	Transmitting a Distress Call	4-30
4.4.16.9	Receiving a Distress Call	4-34
4.4.16.10	Receiving Distress Relay Call	4-35
4.4.16.11	Using the DSC Log	4-36
4.5	Menu Operation	4-37
4.5.1	Selecting the Menu Operation	4-37
4.5.2	NAVSTAT Operation	4-38
4.5.3	DSC Operation	4-39
4.5.3.1	Selecting Distress Call Type (NATURE)	4-10
4.5.3.2	Manual Entry of Latitude/Longitude (L/L/ENT)	4-41
4.5.3.3	Modifying the MMSI Number List (PHNBOOK)	4-43
4.5.3.4	Modifying the MMSI Group Number (GROUP)	4-48
4.5.4	Setting the MMSI Number	4-50
Section 5 Maintenance		
5.1	How to Contact Raymarine	5-1
5.2	Preventive Maintenance	5-3
5.3	Specifications	5-3
5.4	Drawings	5-7
Section 6 Appendix		
6.1	FCC Licensing Requirements	6-1
6.2	Marine VHF Channel Usage Guide	6-3
6.3	Marine VHF Channel Frequency Tables	6-12

GLOSSARY OF TERMS

All Scan	Scans all channels
Canadian Channels	Channel designator as defined by Industry Canada
Carrier Wave	A Radio Frequency on which intelligence is superimposed.
DSC	Digital Selective Calling
Dual Watch	Monitor the Priority Channel (9 or 16) while working on another channel
Duplex	Transmit and receive on different frequencies
FCC	Federal Communications Commission
FM	Frequency Modulation
International Channels	Channel designator as defined by the ITU
ITU	International Telecommunications Union
LCD	Liquid Crystal Display
Memory Scan	Scans only user selected memory channels
MMSI	Maritime Mobile Service Identity; a number issued by each country to identify maritime stations.
NOAA	National Oceanographic and Atmospheric Administration
PLL	Phase Locked Loop (a type of frequency synthesizer)
PTT switch	Microphone push-to-talk switch
RF	Radio Frequency
RTCM	Radio Technical Commission for Maritime Services
RX	Receiver
Simplex	Transmit and receive on the same frequency
Squelch	A circuit that sets the threshold for cutting off the receiver when the signal is too weak for reception of anything but noise
TX	Transmit
Tri-Watch	Monitor the Priority Channel and Weather Channels while working on another channel
US Channels	Channel designations as defined by the FCC
VCO	Voltage Controlled Oscillator
VHF	Very High Frequency 30MHz to 300MHz
Weather Channels	Channels for routine and emergency weather information broadcast by NOAA

Section 1 General Description

1.1 Introduction

Congratulations on your purchase of Raymarine's RAY215 marine radiotelephone. This handbook describes the physical and functional characteristics of the radiotelephone.

The RAY215 is a microprocessor-controlled, digitally synthesized, compact transceiver that provides reliable simplex and semi-duplex (two-frequency) communications. The RAY215 provides two-way communications on Marine channels and reception on 10 separate weather channels. More importantly, the RAY215 has built-in Digital Selective Calling (DSC) in accordance with RTCM standard SC-101 for sending and receiving DSC Distress, All Ships, Individual Ship, and Group calls.

The RAY215 can transmit and receive on all available US, Canadian, and International Marine VHF radiotelephone channels. There are channels that are FCC approved but may only be used by authorized stations for specific purposes, depending on the type of vessel (commercial or non-commercial). Refer to the of Frequency Tables in Section 6, which list all marine VHF channels available in your RAY215. You should familiarize yourself with these tables to ensure proper channel usage.

1.2 Equipment Features

The RAY215 is designed and manufactured to provide ease of operation with excellent reliability. The important built-in features of the equipment are listed below.

- Built-in DSC in accordance with RTCM standard SC-101
- Exclusive circuit that automatically selects 16 or 9 as the Priority Channel when the radio is turned on
- Dedicated key for changing the Priority Channel (16/9)
- Exclusive weather alert feature (when in monitor mode)
- Waterproof to CFR-46 standard for Fist Microphone and Base Station
- Waterproof to JIS-7 standard for Optional Full Function Handset
- Dedicated DISTRESS key on back of handset, with spring loaded protective cover
- All Scan and Memory Scan features
- Dual/Tri-Watch Monitor modes
- Intercom operation between Fist Microphone and Optional Full Function Handset (second station)

- Distant/local mode
- Oversized LCD
- All solid-state circuitry for low current drain and maximum reliability
- Series relay protection on input power circuits to prevent reverse polarity damage
- High-performance receiver section with optimum selectivity

1.3 Microphone / Handset Options

The RAY215 can be operated with the standard Fist Microphone, an optional Full Function Handset with additional features, or both. Operation with both units installed enables intercom capabilities between the two stations.

The Fist Microphone features up/down channel select keys, Priority Channel (16 or 9) selection button, plus a quick access DSC Distress key.

The optional Full Function Handset provides you with all the features of the fist microphone plus a full alphanumeric keypad, expanded LCD display, volume and squelch level controls, DSC distress calls that describe the type of distress, dedicated keys for Individual and All Ships DSC calls, and expanded ship and shore phonebooks for making DSC Individual calls.

Either unit can be located in a remote location using the optional Handset/Microphone Relocation Kit.

The Single Station Full Function Handset with cradle (Raymarine part number E46019) is used in lieu of the Fist Microphone. The Dual Station Full Function Handset (Raymarine part number E46021), which includes a cradle and external speaker, is used in conjunction with the Fist Microphone to enable intercom communications between the two stations.

Note: *The RAY215 is designed to have the base station as the priority unit. Therefore, Raymarine recommends installing the base station in the radio operating room or the location from which the ship is normally navigated. If an optional second station Full Function Handset is also installed, that handset should be installed in the remote location.*

See Section 3 for a complete discussion of operation using the Fist Microphone. Section 4 describes using the RAY215 with the optional Full Function Handset.

Section 2 Installation

2.1 Unpacking and Inspection

Use care when unpacking the unit from the shipping carton to prevent damage to the contents. It is also good practice to save the carton and the interior packing material in the event you must return the unit to the factory.

2.2 Equipment Supplied

The following is a list of materials supplied with the RAY215:

Description	Part No.
RAY215 Radiotelephone	E43003
Fist Microphone with Cradle & Hardware	R49015
Power/Optional Speaker/NMEA Cable	R49017
Mounting Yoke	R49011
Yoke Knob	R49012
Handbook, RAY215	R49013
Sun Cover	R49014

2.2.1 Optional Accessories

The following is a list of options available for the RAY215:

Description	Part No.
Single Station: Full Function Handset with Cradle	E46019
Second Station: Full Function Handset with Cradle 7 meter Handset Extension Cable External Powered Handset Speaker	E46021
Handset/Microphone Relocation Kit	E46026
5m Extension Cable, Full Function Handset	E46018
10m Extension Cable, Full Function Handset	E46017
3m Extension Cable, External Speaker	E46015
External 10W Speaker	E46006
Flush Mounting Kit	E46023
8' Fiberglass VHF Antenna	M51118E

2.3 Planning the Installation

When planning the installation of your RAY215, the following conditions should be considered to ensure dependable and trouble-free operation. Mount the Base Station Transceiver using the Mounting Template provided.

The Base Station Transceiver is designed to be mounted horizontally or vertically on a flat bulkhead. Select a location that is non-metallic, dry, protected, well-ventilated, and free from high operating temperatures and excessive vibration. Provide sufficient space behind the transceiver to allow for proper cable connections to the rear panel connectors. Locate the transceiver as near as possible to the power source yet as far apart as possible from any devices that may cause interference such as motors, generators, and other on board electronics. The transceiver should be protected from prolonged direct exposure to rain and salt spray.

The transceiver is NOT designed to be mounted in engine compartments. Do NOT install the transceiver in a location where there may be flammable vapors (such as in an engine room or compartment, or in a fuel tank bay), water splash or spray from bilges or hatches, where it is at risk from physical damage from heavy items (such as hatch covers, tool boxes, etc.), or where it might be covered by other equipment. Locate the Base Station Transceiver and Handset at least 3 feet from the antenna.

Safe Compass Distance is 1 meter for a common mechanical compass; other compass types may require greater distances. To be sure, you should locate the radio as far as possible from the compass. Test your compass to verify proper operation while the radio is also operating.

Mount the base station transceiver to allow easy access from the location where the ship is normally navigated.

2.3.1 Typical Mounting Methods

The RAY215 can be conveniently mounted on a chart table, bulkhead, overhead, or any other desired location. Refer to Figure 2-1 for typical mounting methods.

CAUTION

Make sure there are no hidden electrical wires or other items behind the desired location before proceeding. Check that free access for mounting and cabling is available.

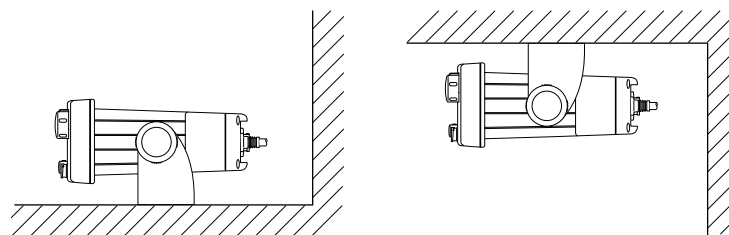

(Table top mount)

(Overhead mount)

Figure 2-1 Typical Mounting Methods

2.3.2 Flush Mounting

In addition to the typical Mounting Methods, the RAY215 may also be flush mounted using the optional Flush Mount Kit. These kits are available from your Raymarine dealer or our Customer Service Department.

There are two methods of mounting the radio using the flush mount kit: from the front or rear of the console. Choose the method that best suits your console.

1. Select the location for the radio transceiver. A clear, flat area, of sufficient height having at least 9" of clear depth behind the panel is required.

CAUTION

Make sure there are no hidden electrical wires or other items behind the desired location before proceeding. Check that free access for mounting and cabling is available.

2. Unpack the Flush Mount kit and confirm that all hardware is present.
3. Mark the cutout area using the cutout guide.
4. Drill a pilot hole inside of the cutout guide area.
5. Using an appropriate saw, carefully cut along the cutout line.
6. Remove the yoke knobs and the mounting yoke from the transceiver. Check that the radio will fit into the cutout area.

Front Mounting

7. Insert the rear of the transceiver through the flush mount bracket such that the tabs on the bracket point away from the radio's front bezel.

8. Continue to push the bracket onto the transceiver until it is flush with the front bezel.
9. On each side of the transceiver, insert a screw through the bracket tab and into the threaded holes from which you removed the yoke knobs.
10. Tighten the screws.
11. It is recommended to run a bead of RTV or similar sealant around the inside edge of the bracket to avoid water entry behind the console.
12. Insert the radio and attached bracket into the cutout.
13. Install four flat head screws through the four countersunk holes in the front of the bracket and secure into the console.
14. From behind the console, connect the power/optional speaker and antenna cables.

Rear Mounting

7. It is recommended to run a bead of RTV or similar sealant around the inside edge of the bezel to avoid water entry behind the console.
8. Insert the radio into the cutout until the front bezel is flush with the console.
9. From behind the console, push the flush mount bracket over the rear of the transceiver such that the tabs on the bracket point away from the radio's front bezel.
10. Continue to push the bracket onto the transceiver until it is flush with the console.
11. On each side of the transceiver, insert a screw through the bracket tab and into the threaded holes from which you removed the yoke knobs but do not fully tighten at this time.
12. Install four pan head screws through the four holes in the bracket and secure the bracket into the console.
13. From the front, make sure the transceiver is still flush with the console.
14. From behind the console, fully tighten the screws that secure the bracket to the radio's threaded yoke knob holes.
15. Connect the power/optional speaker and antenna cables.

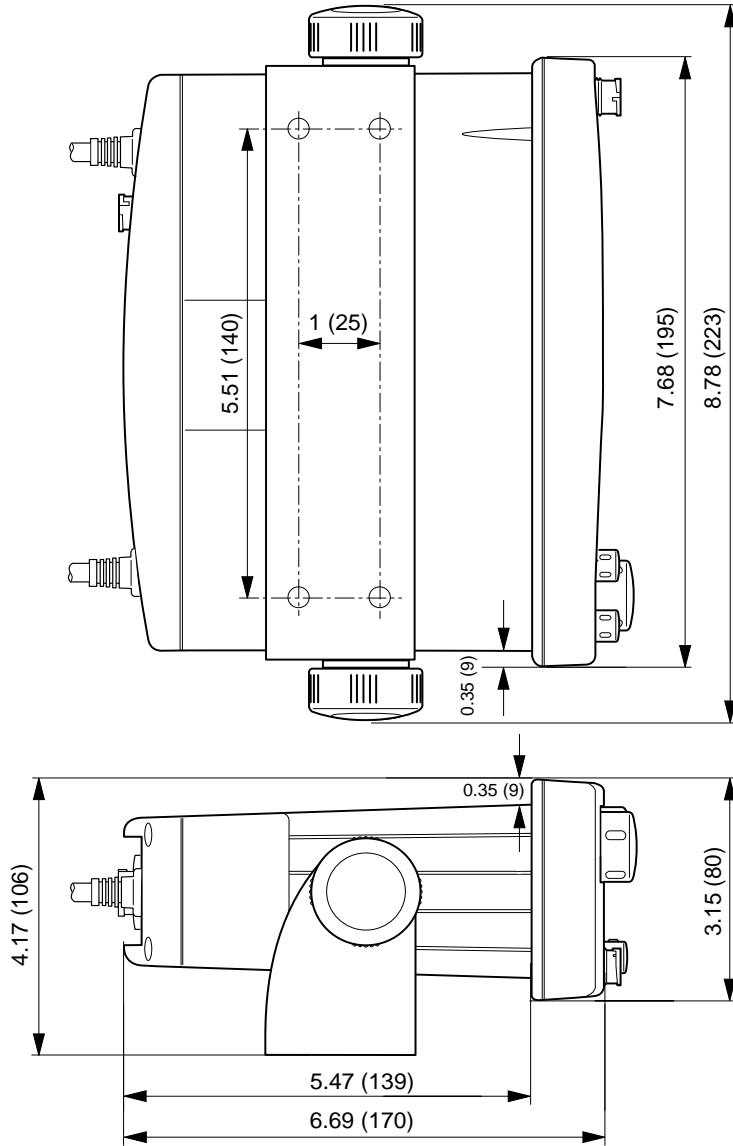

Figure 2-2 Outline and Mounting Dimensions

All dimensions are shown in inches and (millimeters)

2.4 Electrical Connections

2.4.1 DC Power and External Speaker Connections

The 6-foot long power cable is a multi-purpose assembly containing three wire-pairs for connections to DC power, NMEA input, and an optional speaker. Connections to the 6-pin connector are as follows:

Wire Color	Function	Connects to
RED	Power +	Ship's 13.6 VDC power
BLACK	Power -	
YELLOW	Speaker +	External speaker
GREEN	Speaker -	
BLUE	NMEA +	Input from position source (GPS, etc.)
PURPLE	NMEA -	

The RED (+) power wire contains a 10 amp in-line fuse.

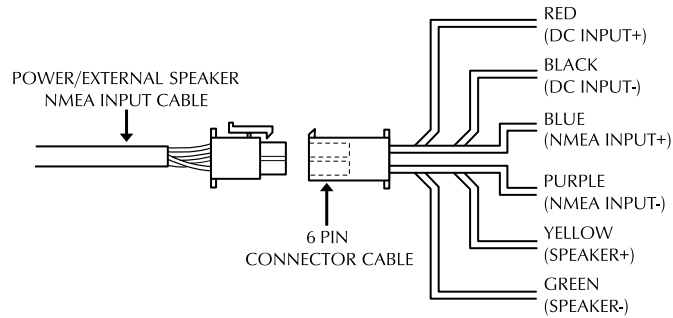

Figure 2-3 Power/External Speaker/NMEA Cable and 6 Pin Connector

In most cases the length of the power cable should be adequate enough to reach the DC power source. If additional wire length is required, the cable can be extended by adding more cable as necessary. However, for power cable runs longer than 15 feet, larger wire diameter size should be used to prevent voltage line loss.

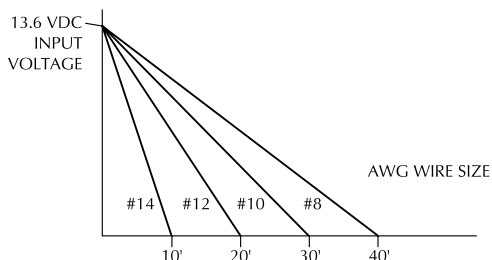

Figure 2-4 Power Cable Length

Your RAY215 should be connected to the nearest primary source of ship's DC power. A typical source may be a circuit breaker on the power panel or a fuse block near the unit. When connecting to either of these sources, the circuit breaker or other in-line fuse should be rated at 10 amps.

It is recommended that lugs be used to connect the power cable to the DC supply and the lug connections should be both crimped and soldered. This is very important in order to ensure adequate current draw to the equipment. Intermittent operation may result if an insufficient connection is made to the power source. The connection terminal should be clean, with no sign of corrosion.

The red (+) wire is connected to the positive terminal of the power source. The black (-) wire is connected to the negative (ground) of the power source. Should the power connections be inadvertently reversed, the unit will not power up but no damage will occur. Check the polarity with a VOM (Voltage/Ohm Meter) and reconnect observing correct polarity. If the fuse ever needs replacement, be sure to use the same type and rating.

2.4.2 External Speaker Connections

The yellow (+) wire and green (-) wire are used for connecting the RAY215 to an external speaker (see Figure 2-3), such as Raymarine's 10W External Speaker (part number E46006).

Four watts of audio output power are provided for an external 4-ohm speaker. A suitable speaker can be purchased from your local marine dealer.

Connect the yellow (+) wire and green (-) wire to the speaker observing polarity as it is marked on the speaker. When connected, the external speaker will function simultaneously with the internal speaker.

CAUTION: DO NOT short the green (-) wire to the yellow (+) wire. DO NOT short the green (-) wire to the black Power (-) wire.

2.4.3 NMEA Data

The RAY215 accepts NMEA 0183 data from a position determining device (GPS, etc.) to provide the Latitude and Longitude position information that is transmitted during a DSC Distress Call.

Connect the input(s) of the positioning device to the blue (NMEA+) and purple (NMEA-) wires in the Power/Optional Speaker/NMEA cable.

An example of how to connect the NMEA cables and power supply using a suitable connector block is shown in the diagram below. For specific instructions how to connect your particular GPS, please refer to the handbook that came with that device.

Note: For non-differential GPS, all return connections (-) must be tied to a common ground reference.

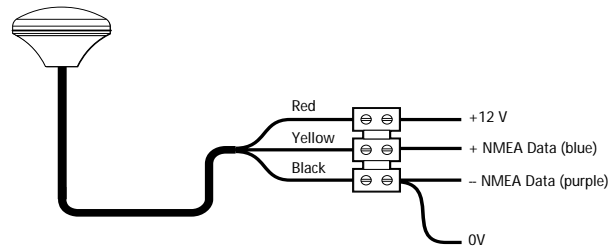

Figure 2-5 GPS Connections

2.4.4 Antenna Connections

Your coaxial VHF antenna cable connects to the RAY215 antenna cable on the rear panel using a PL259 VHF type connector. Your VHF antenna cable length can be critical to performance. If you are uncertain, contact a professional installer or call Raymarine Product Support department. If a longer cable length is required, RG-58 (50 ohm) coaxial cable or equivalent cable can be used for runs up to a maximum of 50 feet. If the distance required is even greater, Raymarine recommends using low loss RG-213 or equivalent cable for the entire run to avoid excessive losses in power output.

If the antenna RF connector is likely to be exposed to the marine environment, a protective coating of grease (Dow Corning DC-4 or similar) can be applied to the connector before connecting it to the radio. Any other extensions or adapters in the cable run should also be protected by silicon grease and then wrapped with a waterproofing tape.

2.4.5 Antenna Mounting Suggestions

The best radio in the world is useless without a quality antenna and good location. Mounting the VHF antenna properly is very important because it will directly affect the performance of your VHF radio. A VHF antenna designed for marine vessels should be used.

- Since VHF transmission is essentially Line-of-Sight, mount the antenna at the highest possible location on the vessel and free of obstruction to obtain maximum range.
- If you must extend the length of the coaxial cable between the antenna and the radio, use a coaxial cable designed for the least amount of power loss over the entire cable length.
- Remember to maintain the recommended minimum 3 feet between the radio and antenna.

2.4.6 Grounding

While special grounding is not generally required for VHF radiotelephone installations, it is good marine practice to properly ground all electronic equipment to the ship's earth ground system. The RAY215 can be connected to ground by attaching a wire to one of the screws on the unit's rear panel and then to the nearest ship's earth ground connection point. The recommended wire to be used for such grounding is #10 AWG.

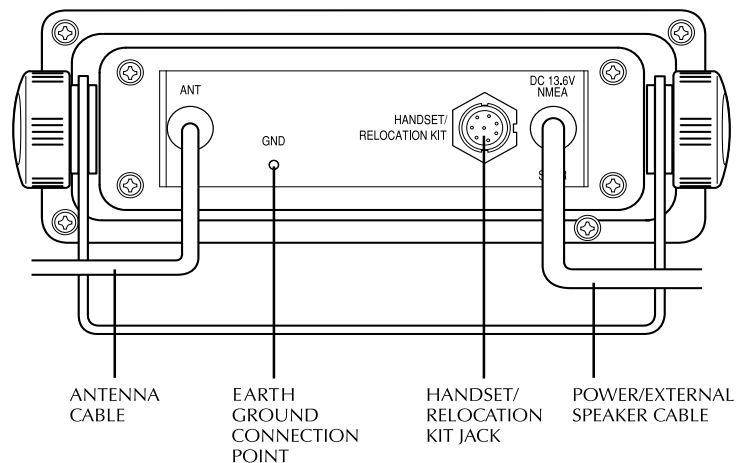

Figure 2-6 Typical Grounding Methods

Section 3 Operation with Standard Fist Microphone

3.1 Introduction

The RAY215 can be operated with the standard Fist Microphone, or an optional Full Function Handset that enables additional features, or both units to enable intercom capabilities. This section describes using the RAY215 with the Fist Microphone. See Section 4 for a discussion of operation using the Full Function Handset.

3.1.1 Microphone / Full Function Handset Priority

When both a Fist Microphone and Full Function Handset are in use, only one can have priority to make a call. When the Full Function Handset is out of its cradle, it has priority over the Fist Microphone and the REMOTE indicator illuminates on the LCD of the base station. When the Full Function Handset is in the cradle, the Fist Microphone has priority and the REMOTE indicator extinguishes.

Overriding the Full Function Handset

In an emergency, the base station can override the Full Function Handset to make a call even though the handset has priority (is off the cradle). To override the handset, press and hold the DSC/PRI key on the base station. The REMOTE indicator flashes and the base station regains priority control. Make your call as usual using the Fist Microphone. On the Full Function Handset, OVERRIDE appears on the dot matrix display. In this mode, all keys are disabled on the handset except for DISTRESS. The base station retains control until the DSC/PRI key is again pressed and held.

Note: *The RAY215 is designed to have the base station as the priority unit. You should install the base station and Fist Microphone in the radio operation room or the location from which the ship is normally navigated. If an optional second station Full Function Handset is also installed, that handset is the one that should be installed in the remote location.*

3.1.2 Microphone/Handset Connections

The Fist Microphone can be connected to the port on the front of the base station (Figure 3-2) or mounted near the base station using the optional Handset Relocation Kit (part number E46026), which is available from your authorized Raymarine dealer/distributor. The Relocation Kit must be connected to the HANDSET/RELOCATION KIT port on the rear of the base station (Figure 3-1).

If both a Fist Microphone and Second Station Full Function Handset are to be used, the Fist Microphone must be connected to the front port with the Full Function Handset connected to the HANDSET/RELOCATION KIT port on the rear. In this case, the Handset Relocation Kit could not be used with the Fist Microphone. Once installed, the two stations can communicate with one another using the Intercom function described in Section 4.4.12.

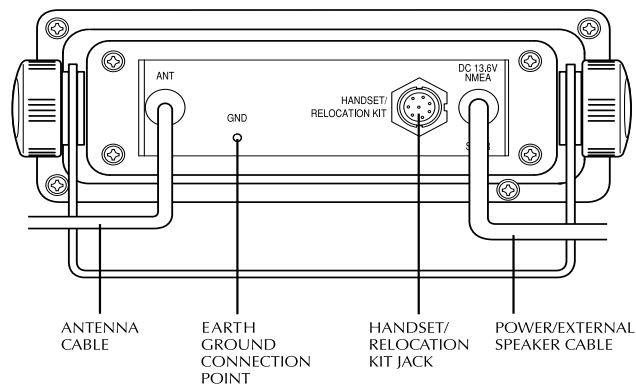

Figure 3-1 Rear Connections

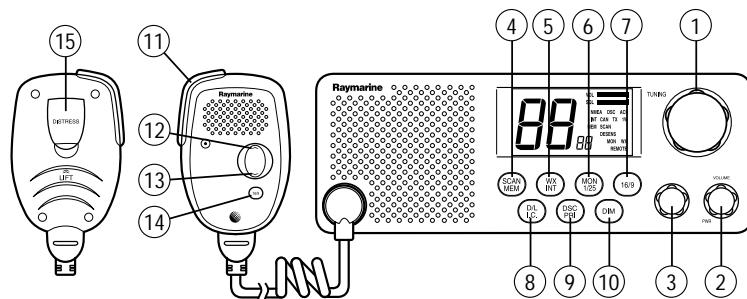

Figure 3-2 Layout of Controls

3.2 Control and LCD Display

3.2.1 Controls

Several of the keys on the front panel of the base station serve multiple purposes. For the most part, the function indicated on the first line of the key is accessed by pressing and releasing that key. The function indicated on the second line of the key is accessed by pressing and holding the key for two seconds.

① CH (Channel Selection) Knob

This knob selects the active channel. Turning the knob clockwise increments the channel number. Turning the knob counterclockwise decrements the channel.

The knob is also used to select values and functions in DSC mode.

② VOLUME/PWR Knob

This knob switches power on and off and controls the audio volume. From the OFF position, rotating the knob clockwise until it "clicks" powers ON the radio. Continuing to turn the knob clockwise, the volume increases. Rotating the knob counterclockwise, the volume decreases. Continuing to turn the knob counterclockwise, the unit "clicks" OFF.

The upper bar graph on the LCD displays the volume level.

③ SQUELCH Knob

This knob controls the squelch sensitivity level. Rotating the knob clockwise increases the squelch level. Rotating the knob counterclockwise decreases the squelch.

The lower bar graph on the LCD displays the squelch level.

④ **SCAN/ MEM Key**

This key starts or stops All Scan and Memory Scan Modes. The key also places favorite channels into the radio's memory for quick selection.

Pressing and holding SCAN/MEM for 3 seconds stores into memory the currently displayed channel and illuminates the MEM indicator on the LCD. If the current channel has already been stored, pressing SCAN/MEM removes the channel from memory and extinguishes the MEM indicator.

Pressing and releasing SCAN/MEM when no channels have been entered into memory initiates a scan of all available channels. The SCAN indicator illuminates on the LCD.

When at least one channel has been programmed into memory, pressing and releasing SCAN/MEM causes the MEM and SCAN indicators to flash for 3 seconds. If the key is pressed again while these indicators are flashing, the radio enters All Scan mode. However, if the 3 seconds expire before pressing the key a second time, the radio initiates a scan of only those channels programmed into memory.

Pressing the SCAN/MEM key during All Scan or Memory Scan terminates the scan.

⑤ **WX/INT Key**

Pressing and releasing WX/INT switches between the Weather channel and the last used marine channel. Pressing and releasing WX/INT while in the Dual Watch mode places the unit in Tri-Watch mode. While in either Weather or Tri-Watch modes, the WX indicator illuminates on the LCD.

Pressing and holding WX/INT for 2 seconds switches between the US, Canadian, and International frequency groups. While in the International Frequency mode, the INT indicator illuminates on the LCD. While in the Canadian mode, the CAN indicator illuminates. There is no indicator for US mode.

⑥ **MON/ 1/25 Key**

Pressing and releasing MON/1/25 initiates the Dual-Watch Monitor mode.

Pressing and holding MON/1/25 for 2 seconds toggles the output power between 1 and 25 watts. While in the 1 Watt mode, the 1W indicator illuminates on the LCD.

Pressing this key while holding PTT overrides the 1W output setting. See the Frequency tables in Section 6 for the affected channels.

⑦ **16/9 Key**

Pressing and releasing 16/9 switches the radio between the current channel and the Priority Channel (9 or 16).

Pressing and holding 16/9 for 2 seconds toggles the Priority Channel between 16 and 9.

⑧ **D/L / I.C. Key**

Pressing and releasing D/L / I.C. switches receiver sensitivity between Distant (full) and Local (desensitized) modes.

While in the Local mode, the DESENS indicator is illuminated.

Holding D/L / I.C. for 2 seconds toggles on and off the Intercom function between the microphone on the base station and an optional remote Full Function Handset. Press PTT to converse with the other station.

⑨ **DSC/ PRI Key**

Pressing and releasing the DSC/PRI and D/L / I.C. keys simultaneously places the radio in DSC mode, which is used to make Individual Ships Calls, Group Calls, All Ships Calls, and Distress Calls.

DSC mode may be exited at any time by pressing the 16/9 key.

Pressing and holding DSC/PRI for 2 consecutive seconds returns Priority control from an optional Second Station Full Function Handset to the base station. This feature is for immediately taking radio operation control from the second station in case of an emergency.

⑩ **DIM Key**

Pressing this key once starts Dimmer mode, which adjusts the brightness of LCD's backlight.

Each successive press of the DIM key switches the brightness from Off, to Low, to Medium, to High, then back to Off.

- ⑪ **PTT Key (Fist Microphone)**
Pressing the PTT (Push To Talk) key enables the radio's transmitter. PTT key operation is disabled when the selected channel is either a Weather channel or a disallowed channel.
- The radio is equipped with a 5 minute timeout timer as a safety feature. After the PTT has been held continuously for 5 minutes, transmission is discontinued and an alarm sounded until PTT is released.
- ⑫ **Trackpad UP Key (Fist Microphone)**
This key increments the channel number by 1 each time it is pressed. If pressed and held, the channel increments at a rate of 10 channels per second.
- ⑬ **Trackpad DOWN Key (Fist Microphone)**
This key decrements the channel number by 1 each time it is pressed. If pressed and held, the channel decrements at a rate of 10 channels per second.
- ⑭ **16/9 Key (Fist Microphone)**
Has the same function as the 16/9 key on the front panel controls.
- ⑮ **DISTRESS Key (under hinged door on rear of microphone)**
The DISTRESS key sends a DSC Distress Call when pressed and held for 5 seconds.

3.2.2 LCD Display

The following describes the functional characters on the RAY215's LCD.

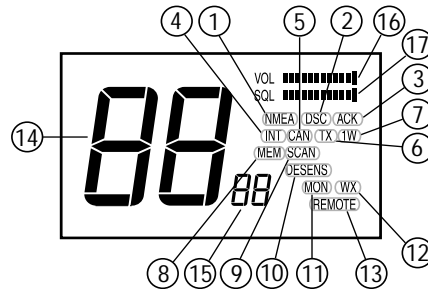

Figure 3-2 LCD Display Layout

- ① **NMEA indicator**
Appears in every operation mode when valid NMEA data is being received.

- ② **DSC indicator**
Appears when the radio is in the DSC mode.
- ③ **ACK indicator**
Appears when receiving an acknowledgement to a DSC Individual or Distress Call.
- ④ **INT indicator**
Appears when the International frequency group is selected.
- ⑤ **CAN indicator**
Appears when the Canadian frequency group is selected.
- ⑥ **TX indicator**
Appears during transmission.
- ⑦ **1W indicator**
Appears when the current transmission output is set at 1W.
(The indicator is extinguished when the output is set at 25W.)
- ⑧ **MEM indicator**
Appears when a channel on the display is stored in memory and during a Memory Scan operation.
- ⑨ **SCAN indicator**
Appears during a scan operation.
- ⑩ **DESENS indicator**
Appears when the radio is in the Desensitized (local) mode.
- ⑪ **MON indicator**
Appears when the radio is in the Dual Watch or Tri-Watch Monitor mode.
- ⑫ **WX indicator**
Appears when the radio is in the Weather Channel or Tri-Watch modes.
- ⑬ **REMOTE indicator**
Appears when the optional, remote Full Function Handset has the priority operation.
- ⑭ **Channel display (Large)**
Displays the current channel number.
- ⑮ **Channel display (Small)**
Displays the Priority Channel number while the radio is in the Monitor mode and function indicators during DSC mode.

- ⑩ **VOL indicator (in bar graph)**
Represents the current sound volume level. A louder volume displays a larger number of segments in the bar graph.
- ⑪ **SQL indicator (in bar graph)**
Represents the current squelch level. A deeper squelch displays a larger number of segments in the bar graph.

3.3 Operating Procedures

3.3.1 Turning the Power On

Rotate the VOLUME/PWR knob clockwise to turn the radio on.

3.3.2 Setting the Squelch

Rotate the SQUELCH knob counterclockwise until audio is heard. Rotate clockwise until the squelch "quiets".

3.3.3 Setting the Volume

With audio present, rotate the VOLUME knob clockwise for the desired volume level.

3.3.4 Setting the Power Output

Press the MON/1/25 key for two seconds to toggle between 1 watt output and 25 watts output. When the 1W indicator is displayed, the output power is 1 watt. If 1W is extinguished, 25 watts is being output.

The choice of power output is dependent upon the distance of transmission and transmitting conditions. In certain US harbors and on certain channels, the FCC requires the power to be limited to 1 Watt. On these "required" channels, the radio automatically selects 1 watt power output when the channel is selected.

3.3.5 Setting the Channel

To select the appropriate channel, rotate the CH (Channel Select) Knob clockwise/counterclockwise or use the Channel UP/DOWN keys on the microphone.

3.3.6 Setting the Frequency Mode

The frequency modes available are US, International, and Canadian. If the CAN and INT indicators are not illuminated, then US channels are selected.

If in US mode, pressing and holding the WX/INT key for 2 seconds will select Canadian channels (CAN will illuminate).

If in Canadian mode and WX/INT is pressed for 2 seconds, INT will display and International channels are selected.

If WX/INT is pressed for 2 seconds while INT is illuminated, INT will disappear and US channels are selected.

3.3.7 Transmitting

Press the Push-To-Talk key (PTT) and speak into the microphone using a clear normal voice. If the current channel is a Weather Channel or a TX prohibited channel, an alarm will sound when PTT is pressed indicating such a transmission is not permitted.

As per FCC rules, if PTT is pressed and held enabling the transmitter continuously for 5 minutes, the RAY215 will automatically disable the transmitter. Once PTT is released, the transmitter will be re-enabled.

3.3.8 Selecting a Weather Channel

The US National Oceanic and Atmospheric Administration (NOAA) broadcasts continuous weather reports and severe weather alerts, as needed. The RAY215 is programmed to receive 10 NOAA weather channels and sound an alarm if a weather alert is received.

The Weather Channels consist of Channel 0 through Channel 9. Press the WX/INT key once to enter the Weather mode and use either the Channel Select (CH) knob or Channel UP/DOWN Trackpad on the microphone to select the desired weather channel. While the Weather Channel is active, the WX indicator appears in the LCD display.

Note: *Weather operation is available only in US frequency mode and can only be heard in the US and Canada.*

3.3.9 Priority Channel

Either channel 16 or 9 can be programmed as the Priority Channel.

To switch to the currently programmed Priority Channel at any time, press the 16/9 key once.

To change the Priority Channel, press the 16/9 key once to switch to the Priority Channel, then press and hold the 16/9 key until a tone is heard. When the Priority Channel is active, a "P" appears in the small character display.

3.3.10 Desensitized Reception (Local Mode)

You can set the RAY215 to reduce the receiving sensitivity in high traffic areas to decrease unwanted reception. This is also known as local mode.

To select this mode, press and release the D/L key. While the desensitize function (local mode) is active, the DESENS indicator appears in the LCD display. To return to full receiver sensitivity (distant mode), again press and release the D/L key.

3.3.11 Channel Memory

The RAY215 can store any US, Canadian, or International Channel. The stored channels are the ones scanned in the Memory Scan mode.

To store a channel in memory, select the desired channel with the CH knob and press and hold the SCAN/MEM key for 2 seconds. A tone sounds and the MEM indicator is displayed. (Weather channels can not be stored into memory).

To clear a channel from memory, select the memory channel and press and hold the SCAN/MEM key for 2 seconds. The MEM indicator extinguishes, indicating that channel is no longer stored in memory.

3.3.12 Resetting Factory Defaults

You can reset many radio settings back to their factory defaults:

- Erase any channels stored in memory for the Memory Scan function
- Erase any MMSI numbers stored in the base station for Individual Ship's Call
- Turn OFF the backlight on the base station and Full Function Handset
- Return to US channels, if INT or CAN are selected
- Return the Weather Channel to channel 0
- Return the Priority channel to channel 16

This will NOT erase the Own Ship's MMSI ID number for your vessel nor will it erase the PHNBOOK entries made with the Full Function Handset.

To perform the memory reset:

1. Turn the radio OFF.
2. Press and hold the SCAN/MEM key.
3. While continuing to hold the SCAN/MEM key, turn the radio ON.
The LCD remains blank for 2 seconds, CL appears momentarily, then the unit switches to channel 16.

3.3.13 Scan Modes

The RAY215 is equipped with two types of scan options: All Scan and Memory Scan. How these options are initiated is dependent upon whether there are any channels stored in memory. Channel 70 is also monitored during Scan mode.

All Scan Mode

If no channels are stored in memory when the SCAN/MEM key is pressed, the radio begins scanning all channels (except weather channels) as long as no signal is received. If a signal is received, the scan stops on the receiving channel as long as it is present. If the signal is lost for five seconds, the radio resumes scanning. SCAN is displayed on the LCD while the Scan mode is active.

If the SCAN/MEM key is pressed again while SCAN is flashing, the All Scan Standby state is suspended and the unit returns to the normal state. To cancel the scan mode, press the SCAN/MEM key once.

Memory Scan Mode

If one or more channels are stored in memory when the SCAN/MEM key is pressed, SCAN and MEM begin to flash simultaneously on the LCD. If no other key is pressed within three seconds, SCAN and MEM stop flashing and the radio begins scanning all channels currently stored in memory. As with All Scan, if a signal is received, the scan stops on the receiving channel until the signal is lost for five seconds, then the radio resumes scanning. To cancel memory scan, press and release SCAN/MEM.

If there are channels stored in memory but All Scan operation is desired, press SCAN/MEM again within the 3 second period while the SCAN and MEM indicators are flashing.

3.3.14 Monitor Mode

The RAY215 is equipped with 2 types of monitor operations: Dual Watch and Tri-Watch.

Dual Watch Mode

Dual Watch monitors the selected working channel and the programmed Priority Channel. To initiate Dual Watch, first select the working channel to be monitored, then press the MON/1/25 key once. The selected working channel and the Priority channel (16 or 9) are monitored for traffic.

If a signal is received on the working or Priority channel, the radio monitors that channel as long as a signal is present. Dual Watch will resume if the signal is lost for 3 seconds. To exit the Dual Watch mode, press the MON/1/25 key to revert to the last used working channel or the 16/9 key to revert to the programmed Priority channel.

Tri-Watch Mode

Tri-Watch monitors the selected working channel, the programmed Priority Channel, and the last used Weather Channel for the Weather Alert Tone. To initiate Tri-Watch, initiate the Dual Watch mode and press the WX/INT key. The WX indicator illuminates on the LCD to indicate the Weather Channel is also being monitored.

Operation is the same as Dual Watch except that if a Weather Alert Tone is received, the radio simultaneously sounds an alarm tone, WX flashes, and the NOAA Weather Alert is monitored.

To exit the Tri-Watch mode, press the MON/1/25 key to switch to the last used working channel or the 16/9 key to switch to the programmed Priority channel. To revert to Dual Watch mode, press the WX/INT key.

3.3.15 LCD Backlight Function

Pressing this key twice starts Dimmer mode, which adjusts the brightness of LCD's backlight. Each successive press of the DIM key switches the brightness from Off, to Low, to Medium, to High, then back to Off.

After the key has not been pressed for 5 consecutive seconds, the currently selected brightness level is stored in memory.

3.3.16 NMEA Operation

The RAY215 can receive valid position and time information, which are transmitted during a DSC Distress call. This data can be communicated via NMEA 0183 from a GPS, fishfinder, radar, or any device that outputs GPS sentences. If the radio does not detect the positional data, it provides different alerts urging you to find and correct the fault. The optional Full Function Handset enables you to manually input this data using the L/L ENT function, as described in Section 4.5.3.2.

If a GPS device is not connected via NMEA, the radio emits a 5-second-long staccato alert tone and flashes the NMEA indicator 2 minutes after power up. This occurs every time the unit is turned on. The alarm is required by safety regulations and cannot be disabled.

Operation at Power Up

At power up, the radio monitors the NMEA line for 1 minute. If a signal is detected on NMEA, the radio determines whether the data is valid. If valid, the data is input, the NMEA indicator is displayed on handsets, and the radio enters normal operation mode.

If no GPS signal is detected on NMEA after the 1 minute monitoring period, a 5-second-long staccato alert tone is emitted and the NMEA indicator flashes. All the position fields are set to 9's and the time and date fields are set to 8's. The message NO GPS appears in the NAVSTAT screen, although no positional data is displayed.

If at a later time valid data is received on NMEA, the data is input, the NMEA indicator is displayed solid (no longer flashing), and the radio enters normal operation mode.

Operation When the Signal is Lost or Becomes Invalid

If positional data that was previously detected becomes invalid or is no longer detected, the radio monitors the NMEA line for 1 minute for it to be restored.

If a signal is restored on the NMEA line and the radio determines the data is valid, the data is input, the NMEA indicator remains illuminated, and the radio re-enters normal operation mode.

However, if no signal is detected, the NMEA indicator flashes and a 5-second-long staccato alert tone is emitted. The last received positional data is retained in memory and can be viewed in the NAVSTAT screen.

The message NO GPS appears in NAVSTAT in the position where the type of device used to be. The NMEA indicator continues to flash until valid positional data is received. If valid positional data (from the same source) is later restored, the NMEA indicator is again displayed solid.

Operation When No Signal Detected for 4 Hours

If no valid positional data is received or input manually within 4 hours of the previous alert, the NMEA indicator continues to flash and the staccato alert tone is again emitted. This pattern is repeated every 4 hours if no positional data has been detected. If no manual input was made during the previous 23.5 hours, all the position fields are set to 9's and the time and date fields are set to 8's.

3.3.17 Digital Selective Calling (DSC)

The Digital Selective Calling (DSC) protocol is a globally applied system used to send and receive digital Distress calls as well as Individual and All Ships calls on channel 70, the dedicated DSC channel for Marine VHF. For a Distress call transmission, your RAY215 takes the position and time information from the input NMEA data along with your Maritime Mobile Station Identifier (MMSI) and converts it into a digital "packet". When transmitted, this digital information lets other ships and shore stations know where you are and that you are in a Distress situation.

Communications in DSC mode include the following:

1. Transmitting/Receiving an Individual Call
2. Transmitting/Receiving an All Ships Call
3. Transmitting/Receiving a Distress Call (without designating type)
4. Receiving a Distress Relay Call (without designating type)

Individual, All Ships and Group DSC calls come in three varieties: ROUTINE for normal calls, SAFETY for advisory alerts, and URGENCY for assistance when life is not in immediate danger. To enable DSC mode, press and release the DSC/PRI and D/L/ I.C. keys simultaneously. The DSC indicator illuminates and a tone sounds. Since the Distress Call (enabled by pressing and holding the Distress Key for 4 consecutive seconds) automatically selects the DSC mode, it is not necessary to press the DSC/PRI and D/L / I.C. to make a distress call.

When a DSC call is received, the radio automatically enters DSC mode if you are currently on a selected working channel, in the Monitor mode, or in the Scan mode. You will not receive a DSC call if the radio is transmitting or receiving a non-DSC call.

Note: You must program the ship's MMSI number before the radio can enter the DSC mode. See Section 3.3.17.1 below.

3.3.17.1 MMSI Number Setup

You must enter your Maritime Mobile Service Identity (MMSI) number in the RAY215 before the DSC system will be operational. You can request an MMSI number from the FCC when you apply for a radio license.

If your vessel does not require a license, you may obtain an MMSI by contacting either BoatUS (www.boatus.com) or MariTEL (www.maritelusa.com).

Once you have received your MMSI number, enter it into the radio as follows:

1. Press and hold the DSC/PRI and D/L / I.C. keys simultaneously for 2 seconds to enter DSC mode. A tone sounds, the DSC indicator appears, "0" is displayed in the large character display, and "1" is displayed in the small character display.

Note: If an MMSI number is already in memory, the MMSI entry scrolls across the display, one digit at a time.

3. Rotate the Channel Select (CH) knob until the first digit of your MMSI number appears in the large character display. (Channel UP/DOWN keys on the microphone are disabled during this process).
4. Press the DSC/PRI key once to accept. The small character display now shows a "2", designating the second digit in your MMSI number.
5. Rotate the Channel Select (CH) knob until the second digit of your MMSI number appears in the large channel display.
6. Press the DSC/PRI key once to accept.
7. Enter all 9 digits of the MMSI number in the same way.

Once the 9th digit has been entered and accepted, the RAY215 plays back the 9 digits (one digit at a time) just entered for proper entry verification.

Note: Ensure the MMSI number entered is correct with this verification playback. Once the number is accepted as outlined in the next step, it cannot be changed except by Raymarine factory representatives.

8. If the number is verified as correct, press and hold the DSC/PRI key for 2 seconds and a tone sounds. Your MMSI number has now been stored in memory.

If the number is incorrect, press the DSC/PRI key once and release. The radio will revert to the beginning of the entry process to start over again. This step can be repeated as many times as required until the number is entered correctly.

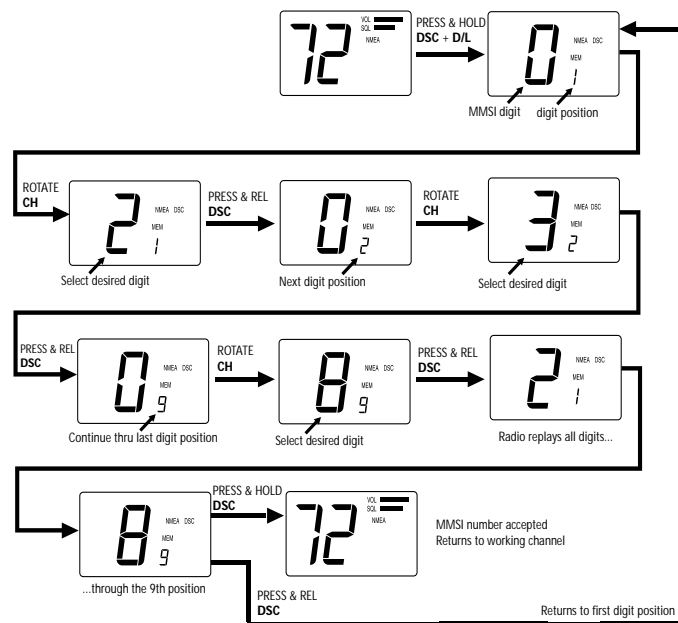

3.3.17.2 Individual Ship's Call

An Individual Ship's Call is a DSC call made to a specific ship identified by its MMSI number. There are three types: ROUTINE for normal calls, SAFETY for advisory alerts, and URGENCY for assistance when life is not in immediate danger.

The RAY215 can receive all three types of Individual calls but can only transmit ROUTINE Individual calls. As with any DSC operation, the call is made on channel 70.

Sending an Individual Ship's Call

The RAY215 can only send a Routine Individual Call. The MMSI number of the ship to which the Individual Call is to be sent can be input manually or selected from a phonebook listing in memory. This section includes instructions for using both methods and for adding numbers to the phonebook.

Using a manually input MMSI number

1. Press and release the DSC/PRI and D/L / I.C. keys simultaneously to place the unit in DSC mode. "70" appears in the large channel display, the DSC indicator illuminates, and "in" appears in the small channel display to designate individual call.
2. Press and release the DSC/PRI key. The DSC indicator appears, "0" is displayed in the large character display, and "1" is displayed in the small character display.
3. Rotate the Channel Select (CH) knob until the first digit of your MMSI number appears in the large character display. (Channel UP/DOWN keys on the microphone are disabled during this process).
4. Press the DSC/PRI key once to accept. The small character display now shows a "2", designating the second digit in the other ship's MMSI number.
5. Rotate the Channel Select (CH) knob until the second digit of the other ship's MMSI number appears in the large channel display.
6. Press the DSC/PRI key once to accept.
7. Enter all 9 digits of the MMSI number in the same way.
8. Once the 9th digit has been entered and accepted, the RAY215 plays back the 9 digits just entered for proper entry verification.

If the number is incorrect, press the DSC/PRI key once and release. The radio will revert to the beginning of the entry process to start over again. This step can be repeated as many times as required until the number is entered correctly.

9. When the MMSI number is verified as correct, press and hold the DSC/PRI key for 2 seconds to verify.

Note: *The operation is cancelled if the 16/9 key is pressed or if no keys are pressed for 60 seconds during any part of this process.*

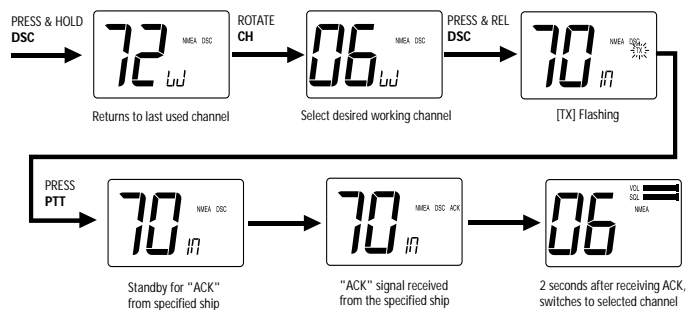

Using an MMSI number selected from the phonebook:

Using the RAY215 with a fist microphone, you can select from up to ten other ship's MMSI numbers that have been stored in the phonebook. The numbers are identified by a single letter that you have assigned to it. You must note what letter you assigned to the MMSI number because only that letter appears on the LCD when you are retrieving it.

Note: The operation is cancelled if the 16/9 key is pressed or if no keys are pressed for 60 seconds during any part of this process.

1. Press and release the DSC/PRI and D/L / I.C. keys simultaneously to place the unit in DSC mode. "70" appears in the large channel display, the DSC indicator illuminates, and "in" appears in the small channel display to designate Individual Call.
2. Press and release the SCAN/MEM key. A letter appears in the small channel display, which is associated with one of the other ship's MMSI numbers in the phonebook.
3. If you wish to use the other ship's MMSI number associated with this letter, press DSC/PRI.
4. To use a different letter, rotate the Channel Selection Knob until the desired letter is displayed. Press DSC/PRI to select this letter.
5. After you have selected the other ship's MMSI number, the radio prompts you for the working channel to communicate on. The large character display shows the last used channel number and a "W" appears in the small channel display.
6. Using the Channel Select (CH) knob on the front panel, select the desired channel, and press the DSC/PRI key once. The TX indicator on the LCD flashes, indicating the RAY215 is ready to transmit.

7. Press the PTT key to send the Individual Ship's Call. After the digital "packet" of information is sent, the radio waits for an acknowledgment from the targeted ship or station.
8. If the target station acknowledges, a tone sounds and "ACK" illuminates on the LCD. After 2 seconds, the RAY215 switches to the previously selected working channel.

OR

If the call is not acknowledged, exit the DSC mode by pressing 16/9.

Note: The operation is cancelled if the 16/9 key is pressed or if no keys are pressed for 60 seconds during any part of this process.

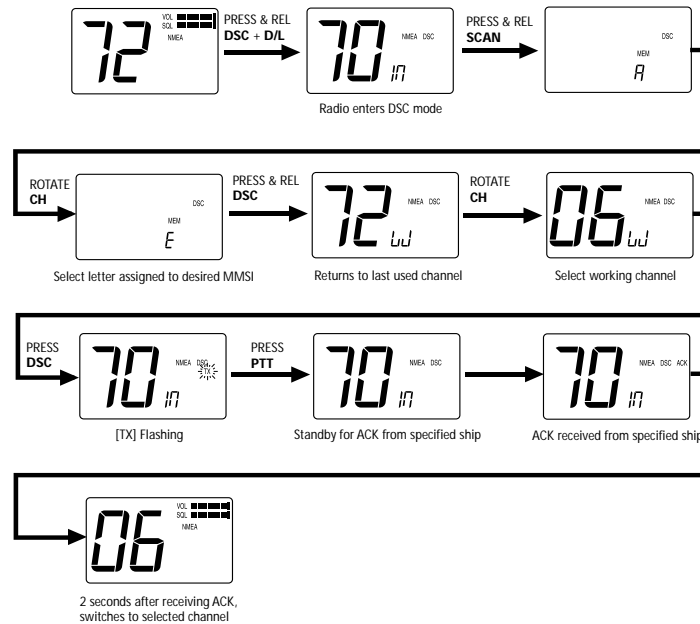

To store an MMSI number in phonebook:

1. Press and release the DSC/PRI and D/L / I.C. keys simultaneously to place the unit in DSC mode. "70" appears in the large channel display, the DSC indicator illuminates, and "in" appears in the small channel display to designate individual call.

2. Press and release the DSC/PRI key. The DSC indicator appears, "0" is displayed in the large character display, and "1" is displayed in the small character display.
3. Rotate the Channel Select (CH) knob until the first digit of your MMSI number appears in the large character display. (Channel UP/DOWN keys on the microphone are disabled during this process).
4. Press the DSC/PRI key once to accept. The small character display now shows a "2", designating the second digit in your MMSI number.
5. Rotate the Channel Select (CH) knob until the second digit of your MMSI number appears in the large channel display.
6. Press the DSC/PRI key once to accept.
7. Enter all 9 digits of the MMSI number in the same way.

Note: *The operation is cancelled if the 16/9 key is pressed or if no keys are pressed for 60 seconds during any part of this process.*

8. Once the 9th digit has been entered and accepted, the RAY215 plays back the 9 digits just entered for proper entry verification.

If the number is incorrect, press the DSC/PRI key once and release. The radio will revert to the beginning of the entry process to start over again. This step can be repeated as many times as required until the number is entered correctly.

9. When the MMSI number is verified as correct, press the SCAN/MEM key. A letter appears in the small channel display.
10. If you wish to assign this letter to the Other Ship's MMSI, press DSC/PRI.
11. If you wish to assign a different letter to the Other Ship's MMSI, rotate the Channel Selection Knob until the desired letter is displayed.
12. Press DSC/PRI to store the MMSI number/letter assignment into the phonebook.

Up to ten Other Ship's numbers can be stored in the phonebook. The letters available are as follows:

ABCDEFCH IJL Pp nOP rStUWJY

You must note what letter you assigned to the MMSI number because only that letter appears on the LCD when you are retrieving it.

Note: No data is stored in memory when a wrong key operation or an interruption of power occurs during the entry procedure. The operation is cancelled if the 16/9 key is pressed or if no keys are pressed for 60 seconds during any part of this process.

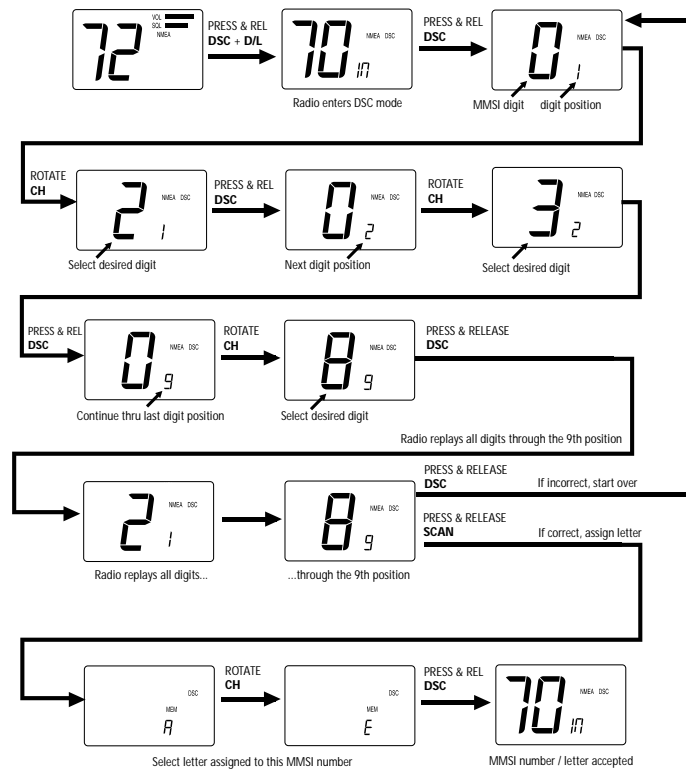

To delete an MMSI number from the phonebook:

1. Press and release the DSC/PRI and D/L / I.C. keys simultaneously.
2. Press and release the SCAN/MEM key.
3. Rotate the Channel Selection Knob until the letter representing the MMSI number to be deleted is displayed.
4. Press and hold D/L/I.C. The selected number is deleted from the phonebook and the radio switches to channel 16.

Receiving an Individual Ship's Call

When an Individual Ship's Call is received, the radio automatically enters DSC mode if you are currently on a selected working channel, in the Monitor mode, or in the Scan mode.

If a received signal is confirmed to be addressed to your own station, an acknowledging signal is sent back. If the received signal is not addressed to your own station, the unit remains in its previous mode without sending an acknowledging signal.

When receiving Individual Ship's Call

1. If your station is targeted for an Individual Ship's Call, a tone sounds and the unit automatically switches to DSC mode. TX flashes on the LCD and one of the following categories of Individual Ship's Calls flashes in the small number display:

"Ir" for ROUTINE Individual Ship's Call

"IS" for SAFETY Individual Ship's Call

"IU" for URGENCY Individual Ship's Call

2. To acknowledge the incoming Individual Ship's Call, press the PTT key. The acknowledge is transmitted and your RAY215 automatically selects the working channel specified by the originating ship or station.
3. If you do not wish to acknowledge the call, press the 16/9 key to exit the DSC mode.

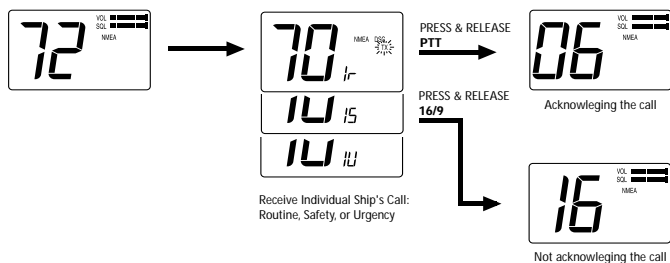

3.3.17.3 All Ships Call

The All Ships Call is used to send out a message to all ships in range that you need assistance but the situation is not serious enough for a Distress Call. This call should only be used if hailing for assistance on channel 9 or 16 fails. There are three types of All Ships Calls: ROUTINE for normal calls, SAFETY for advisory alerts, and URGENCY for assistance when life is not in immediate danger. The RAY215 can transmit and receive all three types of these calls. As with any DSC operation, the call is made on channel 70. Then, after the All Ships Call is sent or received, the radio automatically selects channel 16.

Sending an All Ships Call

1. Press and release the DSC/PRI and D/L / I.C. keys simultaneously to enter the DSC mode.
2. Rotate the Channel Select (CH) knob on the front panel to select the desired type of call. The following appears in the small channel display:
 - "Ar" for ROUTINE All Ships Call
 - "AS" for SAFETY All Ships Call
 - "AU" for URGENCY All Ships Call
3. Press and release the DSC/PRI key and TX begins to flash.
4. Press the PTT key to transmit the All Ships Call. The radio switches to Channel 16.
5. Any station responding to your call converses on Channel 16.

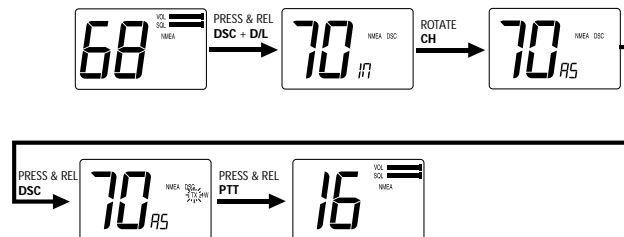

Receiving an All Ships Call

If you are currently on a selected working channel, in the Monitor mode, or in the Scan mode, the radio automatically enters DSC mode when an All Ships Call is received. The type of call is displayed in the small channel display and an alarm is sounded.

Press the DSC/PRI key once and the radio automatically selects channel 16. There is no acknowledge required for an All Ships Call. If you do not wish to accept the call, press the 16/9 key to exit the DSC mode.

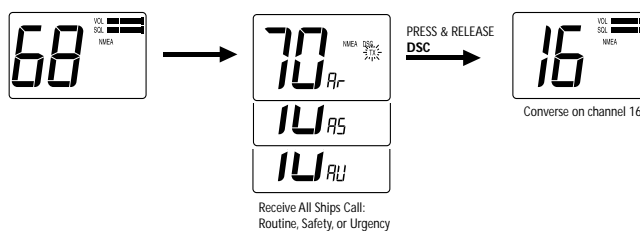

3.3.17.4 Group Call

The Group Call feature sends transmissions that are only received by radios that share a common Group MMSI number.

The RAY215 requires an optional Full Function Handset to program in the Group MMSI number. For this reason, a RAY215 equipped with only a Fist Microphone cannot send or receive Group Calls.

If you have used an optional Full Function Handset to program in the Group MMSI number, you may use a RAY215 equipped with a Fist Microphone to receive Group Calls, even if the Full Function Handset is no longer attached. However, you cannot send Group Calls without the Full Function Handset.

If you are currently on a selected working channel, in the Monitor mode, or in the Scan mode when a Group Call is received, the radio automatically enters DSC mode, sounds an alarm, and displays the type of call as follows:

- "Gr" for ROUTINE Group Call
- "GS" for SAFETY Group Call
- "GU" for URGENCY Group Call

As with any DSC operation, the call is made on channel 70. If a received signal is confirmed to be addressed to the group that your station belongs to, the radio switches to DSC receiving mode and does not send back an acknowledgment. If the received signal is not addressed to the group that your station belongs to, the unit returns to the mode before receiving the Group Call.

After receiving a Group Call, press and release the DSC key to accept the call. The unit switches to channel 16 and extinguishes the DSC indicator, indicating the unit has exited the DSC mode.

The large channel display indicates the working channel and the small channel display is extinguished. If you do not wish to acknowledge the call, press the 16/9 key to exit the DSC mode.

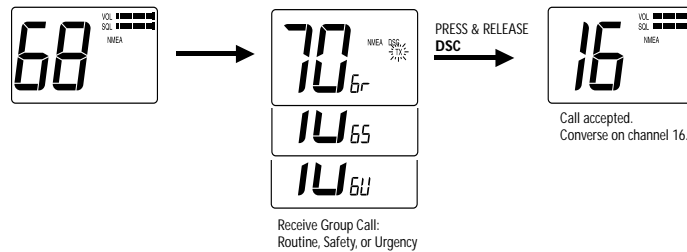

3.3.17.5 Distress Call

A Distress Call allows you to send out a digital "packet" of data at high power that includes your position, time, and MMSI number. All ships and stations outfitted with the correct type of DSC equipment will be able to pinpoint your position and either relay the information or respond directly. Using the Distress key overrides all other functions.

Sending a Distress Call

1. On the back of the microphone, lift the door marked DISTRESS.
2. Press and hold the red Distress key for 5 seconds. After 1 second, the LCD displays a countdown from four to zero, beeping every second.
3. When the countdown has completed, the radio enters the DSC mode, sounds a loud alarm, and sends the digital information at high power. Once transmitted, the radio monitors channel 70 for a Distress acknowledge but also monitors channel 16 for emergency traffic.

Note: When a Distress Call is sent, the unit emits a **VERY LOUD** distress alarm tone. To mute the alarm without interrupting the Distress Call, press the DSC/PRI key on the RAY215 base station. The radio will remain in DSC mode.

4. The Distress Call is automatically re-transmitted every 3.5 to 4 minutes as long as you remain in DSC mode. The radio continues to transmit until either an acknowledge is received or the DSC mode is manually exited by pressing the 16/9 key. The ACK indicator flashes, indicating the radio is monitoring for an acknowledge.
5. If a receiving station has Distress acknowledge capability and sends an acknowledge to you, the DSC tone sounds and the ACK indicator appears solid for 1 second. Next, the radio exits the DSC mode and switches to channel 16 for voice communications.

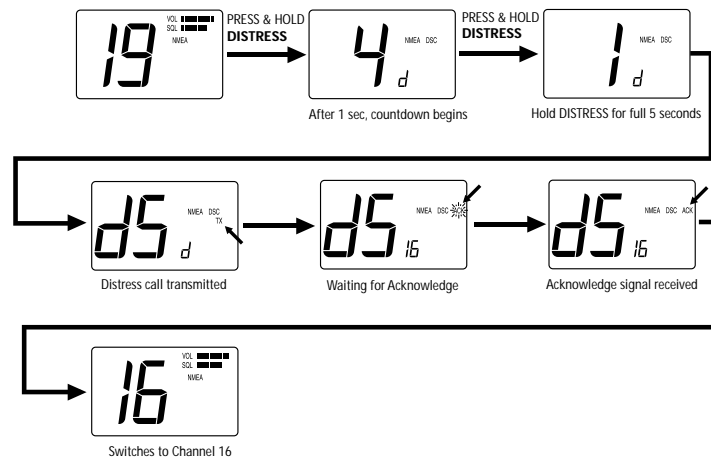

Receiving a Distress Call

When a DSC Distress call is received, the radio automatically enters DSC mode if you are currently on a selected working channel, in the Monitor mode, or in the Scan mode. You will not receive a DSC call if the radio is transmitting or receiving a non-DSC call.

1. When receiving a Distress Call signal, the unit sounds an alarm tone and enters the DSC mode. A "d" flashes in the small channel display for Distress.
2. Press the DSC/PRI key. The radio accepts the call, silences the alarm, and switches to channel 16.

Note: When a Distress Call is received, the unit emits a *VERY LOUD* distress alarm tone. Pressing the DSC/PRI key on the base station mutes this alarm but does *NOT* cancel the Distress Call.

- The RAY215 does not have the ability to acknowledge or relay a DSC Distress Call so once the Distress Call is received, you should attempt to contact the vessel in distress on channel 16 and attempt to render assistance.



3.3.17.6 Distress Relay Call

Sometimes a ship's distress call can be relayed from another ship or a shore station. The RAY215 can only receive a Relayed Distress call; it cannot initiate one.

If the radio is active on a working channel, in the Monitor mode or in the Scan mode when a Distress Relay Call is received, the unit automatically enters DSC mode and emits an alarm tone. The DSC indicator illuminates, 70 is indicated on the large channel display, and "dr" flashes on the small channel display.

Press and release DSC/PRI. The unit switches to channel 16. "16" appears as the working channel on the large channel display while the small channel display is extinguished. The DSC indicator is also extinguished, indicating the unit has exited the DSC mode.

Note: When a Distress Call is received, the unit emits a *VERY LOUD* distress alarm tone. Pressing the DSC/PRI key on the base station mutes this alarm but does *NOT* cancel the Distress Call.

The alert tone continues to sound until DSC/PRI is pressed to accept the call or 16/9 is pressed to exit the DSC mode.



Section 4 Operation with Optional Full Function Handset

4.1 Introduction

The RAY215 can be operated with the standard Fist Microphone, or an optional Full Function Handset that enables additional features, or both handsets to enable intercom capabilities. This section describes using the RAY215 with the optional Full Function Handset. See Section 3 for operation using the standard Fist Microphone.

The Full Function Handset provides you with these additional features:

- Full alphanumeric keypad
- Dedicated keys for Individual and All Ships DSC calls
- DSC distress calls that describe the type of distress
- Send and receive DSC Group Calls
- Expanded ship and shore phonebooks for making DSC Individual calls
- Manually enter lat/lon and UTC time when GPS input is not available
- DSC Call Log

The Full Function Handset option is available as a Single Station (Raymarine part number E46019) that replaces the fist microphone or as a Dual Station (Raymarine part number E46021) that, when used in conjunction with a Fist Microphone, enables intercom functions between the two stations.

The optional Full Function Handset connects to the port labeled HANDSET/RELOCATION KIT on the rear of the base station. The handset will not operate if connected to the microphone port on the front of the base station. If both a Fist Microphone and Full Function Handset are to be used, the Fist Microphone must be connected to the front microphone port and the Full Function Handset connected to the HANDSET/RELOCATION KIT port on the rear of the base station.

4.1.1 Microphone / Full Function Handset Priority

When both a Fist Microphone and Full Function Handset are in use, only one can have priority to make a call. When the Full Function Handset is out of its cradle, it has priority over the Fist Microphone and the REMOTE indicator illuminates on the LCD of the base station. When the Full Function Handset is in the cradle, the Fist Microphone has priority and the REMOTE indicator extinguishes.

In an emergency, the base station can override the Full Function Handset to make a call even though the handset has priority (is off the cradle). To override the handset, press and hold the DSC/PRI key on the base station. The REMOTE indicator flashes and the base station regains priority control. Make your call as usual using the Fist Microphone. On the Full Function Handset, OVERRIDE appears on the dot matrix display. In this mode, all keys are disabled on the handset except for DISTRESS. The base station retains control until the DSC/PRI key is again pressed and held.

Note: *The RAY215 is designed to have the base station as the priority unit. You should install the base station and Fist Microphone in the radio room or the location from which the ship is normally navigated. If an optional second station Full Function Handset is also installed, that handset is the one that should be installed in the remote location.*

4.1.2 Handset Connections

The Full Function Handset connects to the port labeled HANDSET/RELOCATION KIT on the rear of the base station (Figure 4-1). The Full Function Handset will not operate if connected to the port on the front of the base station.

If both a Fist Microphone and Second Station Full Function Handset are to be used, the Fist Microphone must be connected to the front port with the Full Function Handset connected to the HANDSET/RELOCATION KIT port on the rear. In this case, the Handset Relocation Kit could not be used with the Fist Microphone. Once installed, the two stations can communicate with one another using the Intercom function described in section 4.4.12.

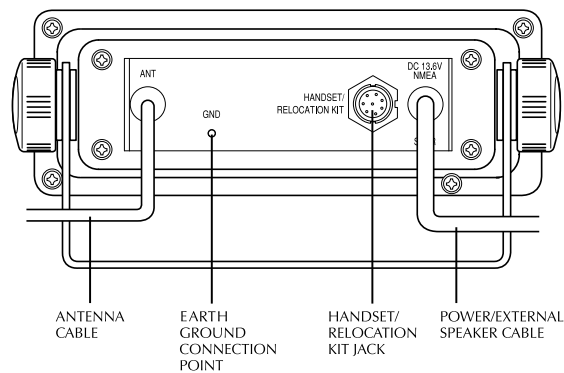

Figure 4-1 Rear Connections

4.2 Controls and LCD Display

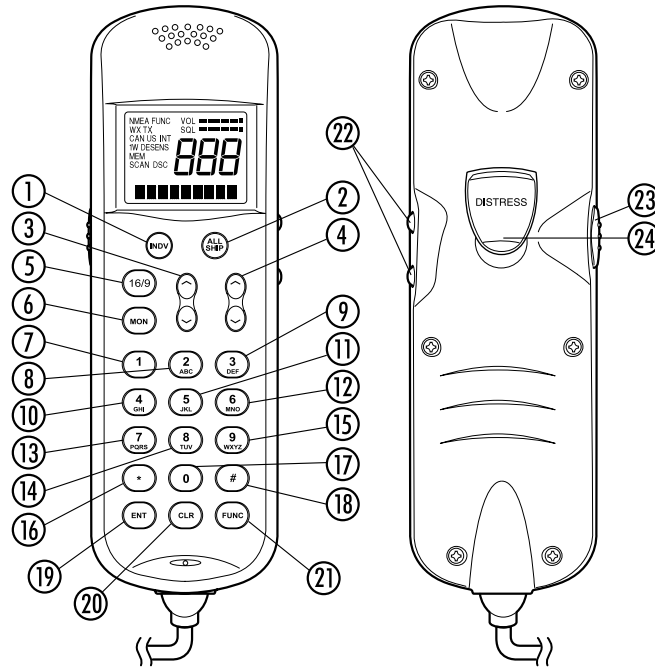

Figure 4-2 Layout of Controls

4.2.1 Controls

This section describes the control buttons and display messages that appear on the Full Function Handset.

Note: *This Full Function Handset is also used with Raymarine radios that have additional features. As a result, the yellow Function labels POWER (16/9 key), CELL (3 key), HAIL (* key), and FOG (# key) represent features that are not available on the RAY215.*

① INDV key

Switches to the DSC Individual Ships Call mode for initiating selective calls (ship-to-ship, group calls, etc.) using a specific MMSI number. Descriptions of these operations appear below in sections 4.4.16.1 and 4.4.16.2.

Note: An MMSI number is required to operate the DSC equipment in this radio. You can program the MMSI number yourself one time only using the Menu Operation described in section 4.5.4 or you can have your Raymarine dealer program the number for you.

- ② **ALL SHIP key**
Switches to the All Ships Call mode for Safety and Urgency transmissions. Descriptions of subsequent operations appear below in section 4.4.16.6 Transmitting All Ships Call.
- ③ **VOL UP/DOWN key**
Changes the sound volume of the handset. Pressing the UP \wedge key increases the volume, while the DOWN \vee key causes it to decrease. The number of segments in the VOL bar graph on the LCD display will increase or decrease accordingly.
- ④ **SQ UP/DOWN (SCROLL) key**
Increases or decreases the squelch sensitivity. Pressing the UP \wedge key increases the squelch, while the DOWN \vee key decreases it. The number of segments in the SQ bar graph on the LCD display will increase or decrease accordingly. This key is also used as a scroll key for selecting menu items and other settings, as described below.
- ⑤ **16/9 key**
Switches between the Working Channel and the Priority Channel. Pressing and holding the key for 2 seconds alternates the Priority Channel between channel 9 and channel 16.
Note: The **POWER** label over this key does not pertain to the RAY215.
- ⑥ **MON/TRI key**
Starts the Dual-Watch monitor mode. Pressing the FUNC key followed by the MON/TRI key initiates the Tri-Watch monitor mode.
- ⑦ **1/MEM key**
This key inputs the number 1. When an alphanumeric response is appropriate, this key alternates between entering a 1 and a space. If the channel number indicated on the LCD display is not currently stored in memory, pressing the FUNC key followed by the 1/MEM key enters that channel number into memory. If the currently indicated channel has already been stored, pressing the FUNC key followed by the 1/MEM key deletes that channel from memory.

⑧ 2/SCAN key

This key inputs the number 2. When an alphanumeric response is appropriate, each press of this key alternately inputs the characters 2, A, B, then C. Pressing the FUNC key followed by the 2/SCAN key toggles Scan mode ON or OFF. Scan mode is described below in section 4.4.13.

⑨ 3 key

This key inputs the number 3. When an alphanumeric response is appropriate, each press of this key alternately inputs the characters 3, D, E, then F.

Note: The *CELL* label over this key does not pertain to the RAY215.

⑩ 4/INT key

This key inputs the number 4. When an alphanumeric response is appropriate, each press of this key alternately inputs the characters 4, G, H, then I. Pressing the FUNC key followed by the 4/INT key alternates the frequency groups from US mode to International mode to Canadian mode.

⑪ 5 key

This key inputs the number 5. When an alphanumeric response is appropriate, each press of this key alternately inputs the characters 5, J, K, then L.

⑫ 6/WX key

This key inputs the number 6. When an alphanumeric response is appropriate, each press of this key alternately inputs the characters 6, M, N, then O. Pressing the FUNC key followed by the 6/WX key alternates between the Working Channel and the Weather Channel.

⑬ 7/D/L key

This key inputs the number 7. When an alphanumeric response is appropriate, each press of this key alternately inputs the characters 7, P, Q, R, then S. Pressing the FUNC key followed by the 7/D/L key toggles between full receiver sensitivity (distant mode) and attenuated receiver sensitivity (local mode). Local mode is used in high traffic areas to decrease unwanted reception. While in local mode (receiver is desensitized), the DESENS indicator appears in the LCD display.

⑭ 8 key

This key inputs the number 8. When an alphanumeric response is appropriate, each press of this key alternately inputs the characters 8, T, U, then V.

- ⑮ **9/ 1/25 key**
This key inputs the number 9. When an alphanumeric response is appropriate, each press of this key alternately inputs the characters 9, W, X, Y, and then Z. Pressing the FUNC key followed by the 9/ 1/25 key alternates the transmission power between 1W and 25W.
- ⑯ *** key**
This key inputs an asterisk (*).
Note: *The **HAIL** label over this key does not pertain to the RAY215.*
- ⑰ **0/IC key**
This key inputs the number 0. Pressing the FUNC key followed by the 0/IC key starts Intercom mode, which enables conversation between the fist microphone connected to the port on the front of the base station and a Full Function Handset connected to the to the port on the rear of the base station. Pressing the FUNC key followed by this key during Intercom mode returns operation to normal mode.
- ⑱ **# key**
This key inputs the # character.
Note: *The **FOG** label over this key does not pertain to the RAY215.*
- ⑲ **ENT key**
This key performs the Enter function. It is used to confirm and implement an input action. Pressing the FUNC key followed by the ENT/MENU key initiates the Menu mode.
- ⑳ **CLR key**
Depending on when it is used, this key exits the current mode and reverts to the last used mode or normal operation. This key also can be used to clear any alphanumeric inputs one at a time in the order that they were entered. Pressing the FUNC key followed by CLR/LOG key initiates the Digital Selective Calling (DSC) Log. Pressing the key during logging returns operation to normal mode.
- ㉑ **FUNC key**
Initiates the Function mode and activates the FUNC indicator in the LCD display. The next key pressed determines the function selected. (See above key descriptions.) Pressing this key twice starts Dimmer mode, which reduces the brightness of LCD's backlight.
- ㉒ **Channel UP/ DOWN key**
Pressing this key during normal operation changes the channel number UP or DOWN.

⑳ PTT (Press-to-Talk) key

Pressing this key during normal operation places the radio in Transmit mode and displays the TX indicator in the LCD. When the key is pressed in various function modes, the assigned operation is initiated.

Note: After 5 minutes of continuously holding the PTT key, the radio will automatically stop transmitting. To begin transmitting again, release the PTT and depress again.

㉑ DISTRESS key

This key is located under the small door labeled DISTRESS on the back of the handset. Pressing and holding this key for 5 seconds selects Distress Signal Call mode. Subsequent operations are described in section 4.4.16.8.

4.2.2 LCD Display

The following describes the functional characters on the RAY215 Handset's LCD.

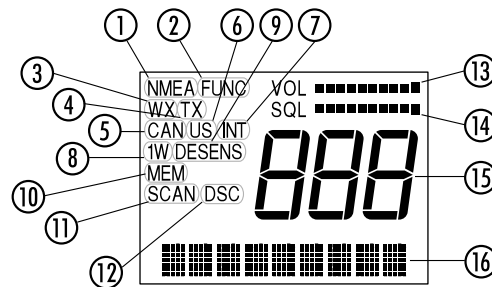

Figure 4-3 LCD Display Layout

① NMEA indicator

Displayed when the radio receives valid NMEA position data. If the data is invalid or no data is received for a period of time, the indicator disappears.

② FUNC indicator

Displayed when the FUNC key is pressed. Disappears when another key is pressed, or after no other key is pressed for a period of time.

③ WX indicator

Displayed while in Weather Channel mode.

- ④ **TX indicator**
Displayed while transmitting.
- ⑤ **CAN indicator**
Displayed when the Canadian frequency group is selected.
- ⑥ **US indicator**
Displayed when the US frequency group is selected.
- ⑦ **INT indicator**
Displayed when the International frequency group is selected.
- ⑧ **1W indicator**
Displayed when the transmission power of 1W is selected with the 9/1/25 key or when a low power channel is selected.
- ⑨ **DESENS indicator**
Displayed during the desensitized receiving (local) mode.
- ⑩ **MEM indicator**
Displayed while the channel stored in memory is displayed. This indicator flashes before the start of the memory scan operation.
- ⑪ **SCAN indicator**
Displayed during Scan mode. If channels have been stored in memory, this indicator will be flashing before the start of Scan mode.
- ⑫ **DSC indicator**
Displayed when in a Digital Selective Calling (DSC) call mode, DSC log, or the DSC menu.
- ⑬ **VOL indicator (in bar graph)**
Represents the current sound volume level of the handset. A louder volume displays a larger number of segments in the bar graph. This bar graph is not displayed during Menu mode.
- ⑭ **SQL indicator (in bar graph)**
Represents the current squelch level. A deeper squelch displays a larger number of segments in the bar graph.
- ⑮ **Three-digit, Seven-segment indicators**
Display the channel number or state of the radio.
- ⑯ **Nine-digit Dot-matrix display**
Displays alphanumeric messages, modes, and functional status of the radio.

4.3 Radio Functions

1. Selecting the Frequency Mode

Channel selection is available from among three frequency groups: US, International, or Canadian.

2. Receiving the Weather Channels

The RAY215 is programmed to receive 10 NOAA weather channels and will sound an alarm if a Weather Alert is received.

3. Selecting the Priority Channel

Select Channel 16 or Channel 9 as the Priority Channel.

4. Dimmer Operation

Select from four LCD backlight levels, including OFF.

5. Monitor Operation

Select from Dual-Watch or Tri-Watch mode.

6. Scan Operation

Select from All Scan or Memory Scan.

7. Selecting Transmission Power Output

Select either 1W or 25W for the transmission power.

8. Digital Selective Calling (DSC) Operation

Conforms to the SC-101 standard for a VHF DSC radio. These functions include Individual Ships Call, All Ships Call, Distress Call, Group Call, and DSC logging capability.

Note: An MMSI number is required to operate the DSC equipment in this radio. You can program the MMSI number yourself one time only using the Menu Operation described in section 4.5.4 or you can have your Raymarine dealer program the number for you.

9. NMEA Receiving Operation

Positional information from external equipment is obtained using the NMEA 0183 interface.

10. Remote Operation

When both a Fist Microphone and Full Function Handset are connected, the RAY215 can be controlled by either the handset or microphone. When the handset is out of its cradle, it has priority over the microphone. When the handset is in the cradle, the microphone has priority and BASE appears on the handset's LCD.

If you need to make a call with the fist microphone while the handset is out of the cradle, press and hold the DSC/PRI key. The fist microphone regains priority control and OVERRIDE appears on the handset's LCD.

11. Intercom Function between Handsets

Intercom mode enables conversation between a first microphone connected to the front of the base station and a Second Station Full Function Handset connected to the rear of the base station.

12. Reduced Receiving Sensitivity (Local Mode)

This function decreases receiver sensitivity in high traffic areas to decrease unwanted reception.

4.4 Operating Procedures

With the Full Function Handset, all operations can be made on the Handset except turning ON/OFF the base station and adjusting the sound volume of the External Speaker.

4.4.1 Setting the Volume

The sound volume adjustment for the handset has 11 settings. Pressing and releasing the VOL UP \wedge key increases the volume by one level; pressing and releasing the VOL DOWN \vee key reduces the volume by one level.

The number of segments in the VOL bar graph on the LCD display will increase or decrease accordingly. If the VOL UP/DOWN keys are pressed and held, the volume levels will automatically change every half-second.

Setting the Volume on the External Speaker

The volume knob on the External Speaker controls its sound volume. Turning the knob clockwise increases the volume; turning it counterclockwise reduces the volume. Turning the knob fully counterclockwise until you hear a “click” switches off the speaker completely.

When a DSC Distress Call is sent or received, an alarm is sounded on the external speaker at maximum volume regardless of the volume set with the knob, even if the knob has been rotated all the way OFF.

4.4.2 Setting the Squelch

The squelch adjustment enables you to “quiet” the receiver when no signal is being received. The squelch adjustment for the handset has 11 settings. Pressing and releasing the SQ UP \wedge key increases the squelch by one level; pressing and releasing the SQ DOWN \vee key decreases it by one level. The number of segments in the SQ bar graph on the LCD display will increase or decrease accordingly. If the SQ UP/DOWN keys are pressed and held, the squelch levels will automatically change every half-second.

4.4.3 Using the Function Key

Most of the keys on the handset control multiple operations. Pressing one of these keys after pressing the FUNC key initiates the operation marked on the label above that key. When the FUNC key is pressed, the FUNC indicator is displayed on the LCD display. If no other key is pressed for 5 seconds, the operation is cancelled and the FUNC indicator disappears.

4.4.4 Setting the Frequency Mode

Select the channel frequency group to be used: US, Canadian, or International. Indicators displayed in the LCD identify the active frequency group: US for the US frequency group, CAN for the Canadian group, and INT for the International group.

Pressing the FUNC key followed by the INT key alternates the frequency groups from US mode to International mode to Canadian mode then back to US mode. When the radio is powered on, the radio is set to the last selected Priority Channel (9 or 16) in the last selected frequency group .

When the frequency group is changed, the channel number remains the same as was selected in the previous group, as long as that number is present in the new group. If a channel number is absent in the destination group, the new channel will be the previous number plus 1. When returning to the previous frequency group, the channel returns to its original number if the channel has not been changed. If the channel has been changed, that number is retained when the frequency group is changed.

Example 1

CH15 US \Rightarrow CH15 INT \Rightarrow CH15 CAN \Rightarrow CH15 US

When shifting the frequency group, the channel remains the same because the corresponding channel number exists in the new frequency group.

Example 2

CH2 CAN \Rightarrow CH3 US \Rightarrow CH2 INT \Rightarrow CH2 CAN

No corresponding channel exists in the new frequency group, so the channel is incremented by 1. As long as the channel is not changed further, it returns to its previous number if the frequency group is again changed.

Example 3

CH2 CAN \Rightarrow CH3 US, then changed to CH5 \Rightarrow CH5 INT \Rightarrow CH5 CAN

However, if the channel is changed in the new frequency group, this new number is retained when the frequency group is changed.

4.4.5 Receiving on the Weather Channels

The US National Oceanic and Atmospheric Administration (NOAA) broadcasts continuous weather reports and severe weather alerts, as needed. The RAY215 is programmed to receive 10 NOAA weather channels and sound an alarm if a weather alert is received.

The Weather Channels consist of Channel 0 through Channel 9. To switch between the Working Channel and the current Weather Channel, press the FUNC key followed by the 6/WX key. While the Weather Channel is active, the WX indicator appears in the LCD display and the frequency group indicator disappears.



If the channel number is changed while in the Weather mode, the new channel number is stored in memory upon exiting Weather mode. To exit Weather Mode, press CLR, or FUNC followed by 6/WX.

Note: *Weather operation is available only in US frequency mode and can only be heard in the US and Canada.*

4.4.6 Selecting the Channel

Two methods are available for selecting the channel: inputting the channel with the numeric keypad then pressing the ENT key, or using the Channel UP/DOWN key on the side of the handset. Both methods are applicable to the three frequency groups on the Working Channel.

Using the Channel UP/DOWN Key

Pressing the Channel UP  key increments the current channel number by one for each keyclick. When the highest channel number is reached, the channel scrolls to the lowest number and increments from there. Pressing the Channel DOWN  key decrements the current channel number by one for each keyclick. When the lowest channel number is reached, the channel scrolls to the highest number and decrements from there. Channel numbers not available in a frequency group are skipped.

If the Channel UP/DOWN key is pressed and held for at least a half second, channels automatically change every 100 milliseconds.

Using the Numeric Keypad

To select a channel, input the desired number on the keypad. For 5 seconds the channel number flashes on the LCD display. If the ENT key is pressed during this 5 second interval, the channel change is implemented.

If the 5 seconds elapse without pressing another key, the channel change is implemented anyway. If the CLR key is pressed while the number is flashing, the channel returns to the previous number.

Note: *A leading zero is required for single digit channel numbers.*

4.4.7 Priority Channel

The Priority Channel operates on either Channel 16 or Channel 9. Pressing the 16/9 key during any operation except the Distress Call switches to the Priority Channel. Pressing and holding the 16/9 key for 2 seconds alternates the Priority Channel between Channel 16 and Channel 9.

While using the Priority Channel, pressing the 16/9 key or the CLR key returns operation to the Working Channel.

4.4.8 Channel Memory

Channels that are stored in memory in the same group can be scanned using the Memory Channel Scan function. Channels can be stored in memory for each frequency group; when the frequency group is changed, the radio operates according to the channels stored in memory for that group.

Storage in memory of Weather Channels or Channel 70 for DSC is disabled. When storage of these channels is attempted, the registration is terminated and an error alert tone sounds.

Storing Channels in Memory

From the Working Channel mode, select the channel to be stored. Press the FUNC key followed by the 1/MEM key. The MEM indicator appears when the registration is complete.

Deleting Channels from Memory

From the Working Channel mode, select the channel to be deleted. Press the FUNC key followed by the 1/MEM key. The MEM indicator disappears when the channel is deleted.

4.4.9 Setting the Transmission Power Output

The transmission output can be set at either 1W or 25W. When the power supply is switched on, the output is 25W. Pressing the FUNC key followed by the 9/1/25 key alternates the transmission between 25W and 1W.

When 1W is selected, the 1W indicator is displayed on the LCD. When 25W is selected the 1W indicator disappears.

4.4.10 Desensitized Reception (Local Mode)

You can set the RAY215 to reduce the receiving sensitivity in high traffic areas to decrease unwanted reception. This is also known as local mode.

To select this mode, press the FUNC key followed by the 7/D/L key. While the desensitize function (local mode) is active, the DESENS indicator appears in the LCD display. To return to full receiver sensitivity (distant mode), again press the FUNC 7/D/L key combination.

4.4.11 LCD Backlight Function

LCD backlight brightness can be set at four different levels. Press the FUNC/DIM key two times to enter Dimmer mode. Each successive click of the FUNC/DIM key alternates the brightness from Off, to Low, to Medium, to High, then back to Off. As the backlight setting is changed, the dot matrix indicator displays the following messages: DIM OFF for the Off setting, DIM LOW for Low, DIM MID for Medium, and DIM HI for High.

When the ENT or CLR keys are pressed or when no other key operation is made for 5 seconds, the current state is accepted and stored in memory, and the backlight setting operation is complete. The next time the power supply is switched on, the state of the backlight is recalled and is applied to each handset individually.

When selecting the DIM OFF setting or pressing any key while in DIM OFF mode, the display is lit at the DIM LOW setting for 5 seconds and then turned off. This is so you can view the display in low light conditions.

4.4.12 Intercom Mode

Intercom mode enables conversation between a fist microphone connected to the port on the front of the base station and a Full Function Handset connected to the port on the rear of the base station.

Note: *Using the Intercom is a simplex operation. You must press PTT to talk to the other station and release PTT to listen.*

Making a Call from the Full Function Handset

1. Press the FUNC key followed by the 0/IC key to enter Intercom mode. IC appears on the large display. While calling, CALLING BASE appears on the dot matrix display.

When the other station answers the call, the message CALLING turns to CONNECT.

Note: *If the other station does not respond within 60 seconds, the unit exits Intercom mode.*

2. Press PTT to speak to the other station and release PTT to listen.
3. To exit Intercom mode, again press FUNC followed by 0/IC.

Making a Call from the Base Station

1. Press and hold the D/L/I.C. key to enter Intercom mode. IC appears on the large channel display. While calling, REMOTE flashes on the small channel display.

When the other station answers the call, REMOTE stops flashing and appears solid.

Note: *If the other station does not respond within 60 seconds, the unit exits Intercom mode.*

2. Press PTT to speak to the other station and release PTT to listen.
3. To exit Intercom mode, again press and hold the D/L/I.C. key.

Receiving a Call with the Full Function Handset

1. When an Intercom call is received, the handset speaker and external handset speaker both emit a calling tone. If the handset is on the cradle, the calling tone is not emitted from the handset speaker.

IC appears on the large display and CALL FROM BASE flashes on the dot matrix display.

2. To answer the call, press PTT. The calling tone ceases and the dot matrix display goes blank.

Note: *If not answered within 60 seconds after being called, the call terminates and the display returns to its previous state.*

3. Press PTT to speak to the other station and release PTT to listen.
4. To exit Intercom mode, again press FUNC followed by 0/IC.

Receiving a Call at the Base Station

1. When an Intercom call is received, the base station speaker emits a calling tone. IC appears on the large channel display and REMOTE flashes on the small channel display.
2. To answer the call, press PTT. The calling tone ceases and REMOTE stops flashing and appears solid.

Note: *If not answered within 60 seconds after being called, the call terminates and the display returns to its previous state.*

3. Press PTT to speak to the other station and release PTT to listen.
4. To exit Intercom mode, again press and hold the D/L/I.C. key.

4.4.13 Scan Mode

During Scan mode, the RAY215 searches through the channels, stops when radio traffic is detected, then resumes scanning after the traffic ceases. Two scan functions are available: All Channel Scan and Memory Channel Scan. The All Channel Scan function searches all channels (except Weather Channels or Channel 70) within the same frequency group. The Memory Channel Scan searches only the channels stored in memory in the same group.

The scan begins from the channel following the one currently indicated. The scan is suspended when a carrier is detected. Five seconds after the carrier ceases, the scan resumes with the next channel. If the carrier is detected again before 5 seconds elapse, the timer is re-initialized. Press the 2/SCAN key to resume the scan from the next channel. To cancel the scan, press the CLR key or press FUNC followed by 2/SCAN.

Upon reaching Channel 88, the radio scrolls back to Channel 1 and continues the scan. If the scan stops on a channel with traffic and you wish to communicate with the other party, press the PTT key to cancel the scan and remain on that channel.

Note: *Both Scan functions exclude Channel 70, which is used exclusively for receiving and transmitting Digital Selective Calling (DSC) functions.*

Using Memory Scan

This function is available only when at least one channel has been stored in memory. Press the FUNC key followed by the 2/SCAN key. The messages MEM and SCAN flash for 3 seconds on the LCD. A scan of only the channels in memory is initiated when the 3 seconds elapse or when you press the ENT key before the 3 seconds elapse.

To cancel the scan, press the CLR key or press FUNC followed by 2/SCAN.

Using All Scan

Press the FUNC key followed by the 2/SCAN key. The messages MEM and SCAN flash for 3 seconds on the LCD. Before the 3 seconds elapse, press the 2/SCAN key again to begin All Scan. If the 3 seconds elapse before you press the 2/SCAN key, the radio will enter Memory Scan.

To cancel the scan, press the CLR key or press FUNC followed by 2/SCAN.

4.4.14 Monitor Mode

Monitor operation can be implemented in one of two modes: Dual-Watch or Tri-Watch.

Dual-Watch

In Dual-Watch Mode, the RAY215 operates on the Working Channel while constantly monitoring the Priority Channel. The radio locks onto the Priority Channel or the Working Channel whenever it becomes active, then returns to Dual-Watch when there is no activity.

To start Dual-Watch Mode, select the desired Working Channel then press the MON key. The Working Channel is displayed on the 7-segment display and the Priority Channel appears on the right side of the dot matrix display.

To end Dual-Watch mode at the current channel, press the MON key or the CLR key. If Dual-Watch mode is initiated at Channel 70, the operation is cancelled and an error alert sounds.

Tri-Watch

In Tri-Watch Mode, the RAY215 operates on the Working Channel while constantly monitoring the Priority Channel then the previously selected Weather Channel for severe weather alert broadcasts. When a signal is detected on the Working Channel or Priority Channel, that channel becomes active. When there is no longer any activity on the Working Channel or Priority Channel, the RAY215 returns to Tri-Watch.

If a weather alert broadcast is detected, the RAY215 emits an alert tone and the WX indicator blinks. Tri-Watch mode terminates and the radio switches to the WX channel to monitor the severe weather broadcast.

To start Tri-Watch mode, select the Working Channel then press the FUNC key followed by the MON/TRI key. The Working Channel appears on the 7-segment display, the Priority Channel appears on the right-most portion of the dot matrix display, and the Weather Channel appears on the left-most portion of the dot matrix display.

To end Tri-Watch mode at the current channel, press the MON key or the CLR key. If Tri-Watch mode is initiated at Channel 70, the operation is cancelled and an error alert tone sounds.

4.4.15 NMEA Operation

The RAY215 can receive valid position and time information, which are transmitted during a DSC Distress call. This data can be communicated via NMEA 0183 from a GPS, fishfinder, radar, or any device that outputs GPS sentences. If the radio does not detect the positional data, it provides different alerts urging you to find and correct the fault or manually input the data using the radio's L/LENT function, as described in section 4.5.3.2. Current valid positional data, whether from external device or manually input, can be viewed using the NAVSTAT Operation described in section 4.5.2.

If a GPS device is not connected via NMEA, the radio emits a 5-second-long staccato alert tone and flashes the NMEA indicator 2 minutes after power up. This occurs every time the unit is turned on. The alarm is required by safety regulations and cannot be disabled.

Operation at Power Up

At power up, the radio monitors the NMEA line for 1 minute. If a signal is detected on NMEA, the radio determines whether the data is valid. If valid, the data is input, the NMEA indicator is displayed on handsets, and the radio enters normal operation mode.

If no GPS signal is detected on NMEA after the 1 minute monitoring period, a 5-second-long staccato alert tone is emitted and the NMEA indicator flashes. All the position fields are set to 9's and the time and date fields are set to 8's. The message NO GPS appears in the NAVSTAT screen, although no positional data is displayed.

If at a later time valid data is received on NMEA, the data is input, the NMEA indicator is displayed solid (no longer flashing), and the radio enters normal operation mode.

Operation When the Signal is Lost or Becomes Invalid

If positional data that was previously detected becomes invalid or is no longer detected, the radio monitors the NMEA line for 1 minute for it to be restored.

If a signal is restored on the NMEA line and the radio determines the data is valid, the data is input, the NMEA indicator remains illuminated, and the radio re-enters normal operation mode.

However, if no signal is detected, the NMEA indicator flashes and a 5-second-long staccato alert tone is emitted. The last received positional data is retained in memory and can be viewed in the NAVSTAT screen. The message NO GPS appears in NAVSTAT in the position where the type of device used to be. The NMEA indicator continues to flash until valid positional data is received. If valid positional data (from the same source) is later restored, the NMEA indicator is again displayed solid.

Operation When No Signal Detected for 4 Hours

If no valid positional data is received or input manually within 4 hours of the previous alert, the NMEA indicator continues to flash and the staccato alert tone is again emitted. This pattern is repeated every 4 hours if no positional data has been detected. If no manual input was made during the previous 23.5 hours, all the position fields are set to 9's and the time and date fields are set to 8's.

4.4.16 Digital Selective Calling (DSC)

The Digital Selective Calling (DSC) protocol is a globally applied system used to send and receive digital Distress calls as well as Individual and All Ships calls on channel 70, the dedicated DSC channel for Marine VHF. For a Distress call transmission, your RAY215 takes the position and time information from the input NMEA data along with your Maritime Mobile Station Identifier (MMSI) and converts it into a digital "packet". When transmitted, this digital information lets other ships and shore stations know where you are and that you are in a Distress situation.

Communications in DSC mode include the following:

1. Transmitting/Receiving an Individual Call
2. Transmitting/Receiving a Group Call
3. Transmitting/Receiving an All Ships Call
4. Transmitting/Receiving a Distress Call
5. Receiving a Distress Relay Call

DSC transmission and reception occurs on Channel 70. When the DSC signal is received, the unit quickly switches over to Channel 70 and performs the corresponding operation. You will not receive a DSC call if the radio is transmitting or receiving a non-DSC call.

Note: An MMSI number is required to operate the DSC equipment in this radio. You can program the MMSI number yourself one time only using the Menu Operation described in 4.5.4.2 MMSI Number Set Up. Otherwise, your Raymarine dealer can program or change the number for you.

Individual, All Ships and Group DSC calls come in three varieties: ROUTINE for normal calls, SAFETY for advisory alerts, and URGENCY for assistance when life is not in immediate danger.

4.4.16.1 Individual Call to Another Ship (Ship-to-Ship)

An Individual Ship's Call is a DSC call made to a specific ship identified by its MMSI number. The RAY215 can receive all three types of Individual calls but can only transmit ROUTINE Individual calls. As with any DSC operation, the call is made on channel 70.

Transmitting an Individual Call

To call another ship, you must select the Working Channel and a specific MMSI number. The MMSI number is selected either manually or from a Phonebook list of preprogrammed numbers specified using the MENU function. To cancel the call, press and hold the CLR key for 3 seconds.

Press the INDV key to initiate the call data setup operation. After setting the call data, press the PTT key to send the call.

To Make an Individual Call to Ship (ship-to-ship):

1. Press the INDV key. **Ind** appears on the 7-segment display and the DSC indicator is displayed. Pressing the SQ UP/DOWN key alternates between SHIP and SHORE.

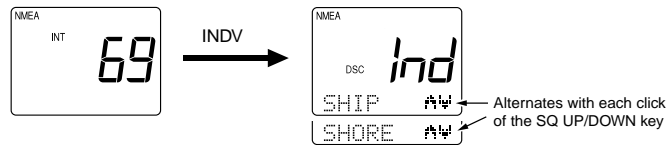

2. Select SHIP and press the ENT key.

3. Scroll with the SQ UP/DOWN keys to select the method for inputting the MMSI number, either from the Phonebook or manually. Press ENT.

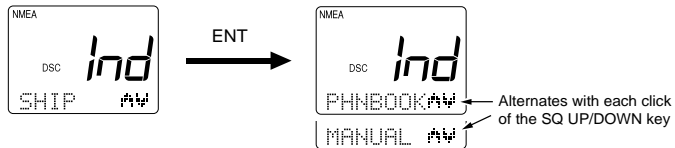

4. Select the MMSI number.

BY PHONEBOOK:

Scroll with the SQ UP/DOWN keys, select the name associated with the desired MMSI number, and press the ENT key. If the MMSI number is not listed in phonebook, the display reverts to manual input.

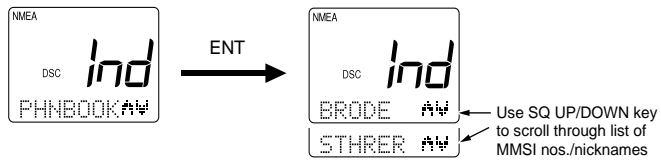

Note: The Full Function Handset provides you with a phonebook that holds entries for up to 20 Ship stations and 20 Shore stations. These are separate from the 10 phonebook entries stored in the base station using the fist microphone (see section 3.3.17.2). These 10 entries cannot be selected with the Full Function Handset.

BY MANUAL INPUT:

Input the 9-digit MMSI number with the numeric keypad, then press the ENT key.

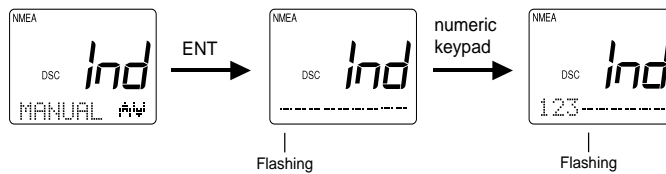

5. Specify the Working Channel with the SQ UP/DOWN keys and press the ENT key.

Note: The working channel selected for the Individual Call is inserted as the working channel as long as it is an inter-ship simplex channel. If it is not, the radio selects the next higher simplex channel to insert as the working channel.

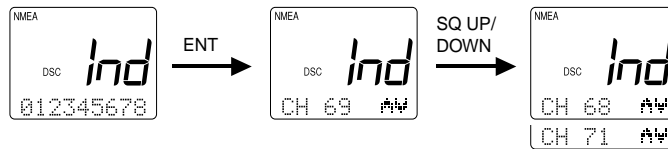

6. Press the ENT key again. A prompt appears on the display instructing you to press the PTT key.
7. Press PTT to transmit.

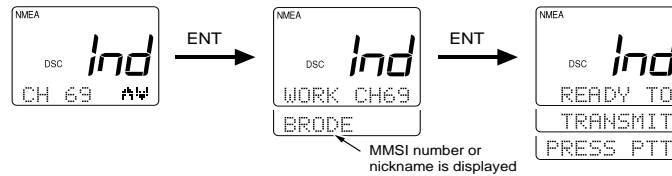

Note: Only simplex channels (those channels that transmit and receive on the same frequency) can be selected for ship to ship Individual Calls. Pressing the SQ UP/DOWN will scroll you through the simplex channels usable for this operation.

Response

If a response is received after pressing the PTT key, a receive-confirmation message is displayed. After 5 seconds have elapsed, the channel is changed to a communication channel and the Individual Ships Call is completed.



If no response is received for 3 minutes after pressing the PTT key, a prompt to press the PTT key appears once more. After 15 seconds elapses without pressing the PTT key following the prompt, operation returns to the state before the call.

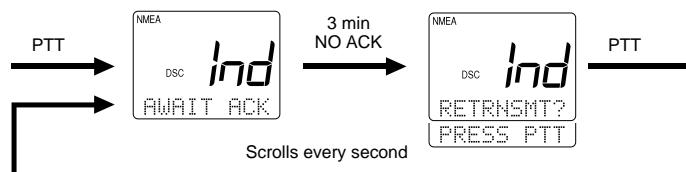

4.4.16.2 Individual Call to Shore Station (Ship-to-Shore)

To call a shore station, you must select the specific MMSI number. The MMSI number can be entered manually or selected from a Phonebook list of preprogrammed numbers. Channel 16 is automatically assigned for communications. To cancel the call, press and hold the CLR key for 3 seconds.

To make an Individual Call to Shore Station (ship-to-shore):

1. Select the Shore Station channel.
2. Press the INDV key. **Ind** appears on the 7-segment display and the DSC indicator is displayed. Pressing the SQ UP/DOWN key alternates between SHIP and SHORE.

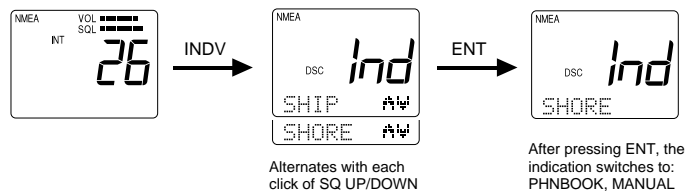

3. Select SHORE and press the ENT key.
4. Scroll with the SQ UP/DOWN keys to select the method for inputting the MMSI number, either from the phonebook or manually. Press ENT to input your selection.
5. Select the name by MMSI number from the phonebook by scrolling with the SQ UP/DOWN keys, and pressing the ENT key.

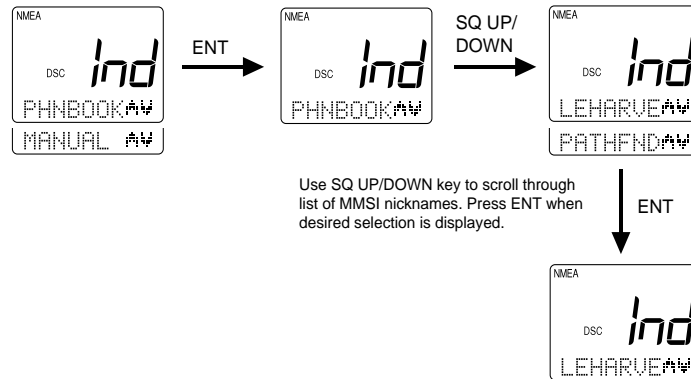

Note: The Full Function Handset provides you with a phonebook that holds entries for up to 20 Ship stations and 20 Shore stations. These are separate from the 10 phonebook entries stored in the base station using the first microphone (see section 3.3.17.2). These 10 entries cannot be selected with the Full Function Handset..

or

Manually input the MMSI number with the numeric keypad, then press the ENT key.

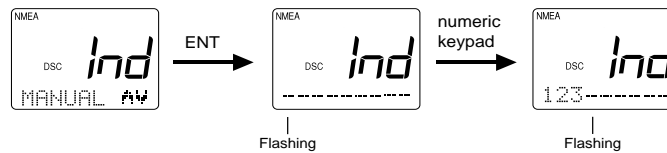

6. Press ENT again. A prompt appears on the display instructing you to press the PTT key.
7. Press PTT to transmit.

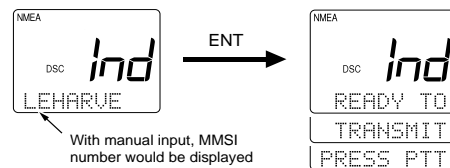

Response

If a response is received after pressing the PTT key, a receive-confirmation message is displayed. After 5 seconds have elapsed, the channel is shifted to a communication channel and the Individual Call is completed.

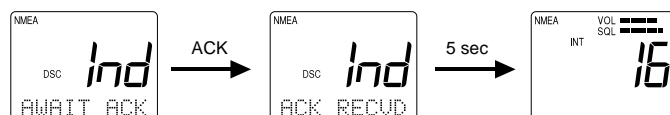

If no response is received for 3 minutes after pressing the PTT key, a prompt to press the PTT key appears once more. If the PTT key is not pressed within 15 seconds after the prompt appears, operation returns to the state before the call.

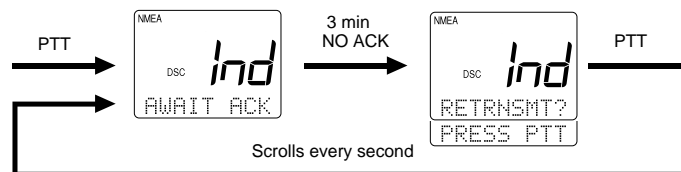

4.4.16.3 Receiving an Individual Call

When an Individual Call is received, the DSC indicator flashes, **Ind** appears on the 7-segment display, and the DSC Received Alert is sounded. On the dot matrix display appears the message RECEIVED IND CALL along with the type of call: ROUTINE, SAFETY, or URGENCY. If the MMSI number exists in the Phonebook list, the associated name is also displayed. If no match is found, the actual numeric value of the MMSI is displayed. Lastly appears a prompt to press ENT to accept or CLR to log the call. This sequence scrolls every second.

Until either the ENT key or the CLR key are pressed, the prompt is flashed at 1-second intervals and is accompanied by an alarm for up to 3 minutes. If neither ENT nor CLR are pressed during these 3 minutes, the radio reverts to the operation mode before receiving the Individual Call. The DSC indicator continues to be flashed on the LCD display until the contents of the log files can be confirmed.

If ENT is pressed, the alarm is turned off, and a new prompt appears on the display, instructing you to press the PTT key. Press PTT to transmit an acknowledgment (ACK). If PTT is not pressed within 5 seconds of the prompt appearing, the transmission is done automatically. Pressing the PTT key causes the channel to change to the communication channel.

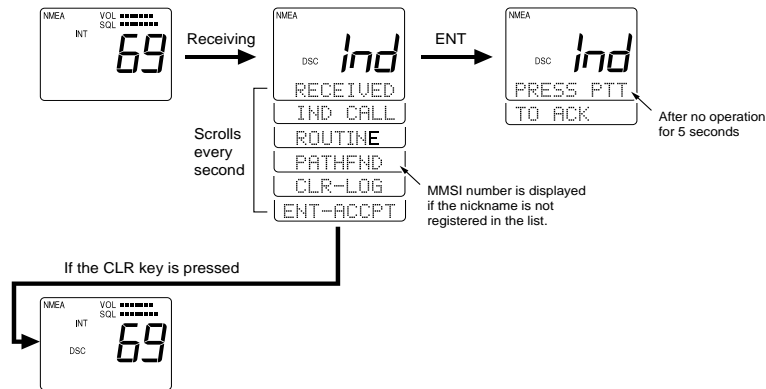

If the CLR key is pressed, the alarm is turned off, the displays are cleared, and the received contents are stored in the Log File. The radio then reverts to the operation mode before receiving the Individual Call.

4.4.16.4 Transmitting a Group Call

You can send and receive DSC calls from groups of stations that share the same Group MMSI number.

The RAY215 can only transmit ROUTINE Group calls. As with any DSC operation, the call is made on channel 70.

To make a Group Call:

1. Set up the Group MMSI number as outlined in section 4.5.3.4.
2. Press the INDV key. **Ind** appears on the 7-segment display, the DSC indicator is illuminated, and SHIP appears on the dot matrix display.
3. Press the SQ UP/DOWN key to alternate between SHIP, SHORE, and GROUP. Stop on GROUP. The GROUP message only appears if you have set up the Group MMSI number as outlined in section 4.5.3.4.

- When GROUP appears, press the ENT key. **GrP** appears on the 7-segment display and the registered Group MMSI number appears on the dot matrix display.

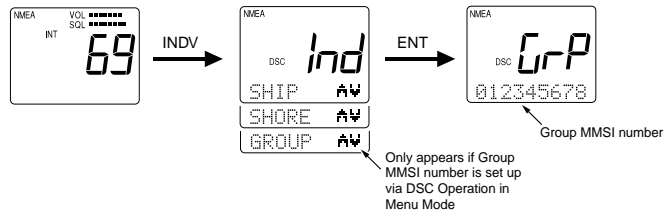

Note: Since only one group MMSI number can be registered at a time, only one MMSI number can be displayed when GROUP is selected. To change the group MMSI number, see section 4.5.3.4.

- Press ENT to accept the MMSI number.
- Use the SQ UP/DOWN key to select the Working Channel for communication.
- When the desired channel number appears, press ENT. The dot matrix display scrolls between the Working Channel and the Group MMSI number.
- If this information is correct, press ENT to accept. A new message appears, prompting you to press the PTT key.
- Press PTT. The radio changes over to the selected Working Channel without waiting for acknowledgment.

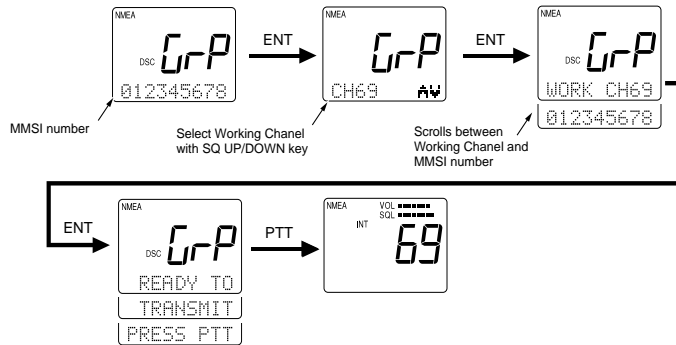

4.4.16.5 Receiving a Group Call

When a Group Call is received, the DSC indicator flashes, **Grp** appears on the 7-segment display, and the DSC Received Alert is sounded. On the dot matrix display appears the message RECEIVED GRP CALL, along with the type of call: ROUTINE, SAFETY, or URGENCY. If the MMSI number exists in the list, the associated name is displayed. If no match is found, the actual numeric value of the MMSI is displayed. You are then prompted to press ENT to accept or CLR to log the call.

Until either the ENT key or the CLR key are pressed, the prompt is flashed at 1-second intervals and is accompanied by an alarm for up to 3 minutes. If neither ENT nor CLR are pressed during these 3 minutes, the radio reverts to the operation mode before receiving the Group Call. The DSC indicator continues to be flashed on the LCD display until the contents of the log files can be confirmed.

If ENT is pressed, the alarm is turned off, and a new prompt appears on the display, instructing you to press the PTT key. Press PTT to transmit. If PTT is not pressed within 5 seconds of the prompt appearing, the transmission is done automatically. Pressing the PTT key causes the channel to change to the communication channel.

If the CLR key is pressed, the alarm is turned off, the displays are cleared, and the received contents are stored in the Log File. The radio then reverts to the operation mode before receiving the Group Call.

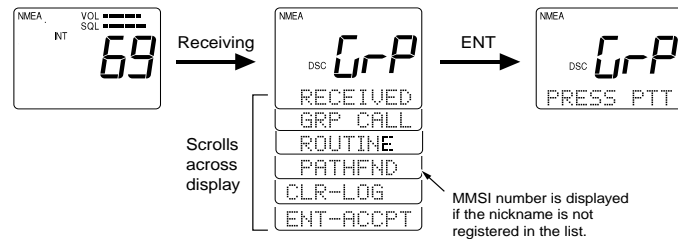

4.4.16.6 Transmitting an All Ships Call

The All Ships Call is used to send out a message to all ships in range that you need assistance but the situation is not serious enough for a Distress Call. This call should only be used if hailing for assistance on channel 9 or 16 fails. The RAY215 can transmit and receive all three types of All Ships Calls: ROUTINE, SAFETY, and URGENCY. As with any DSC operation, the call is made on channel 70. Then, after the All Ships Call is sent or received, the radio automatically selects channel 16.

To send an All Ships Call

1. Press the ALL SHIP key. The message SAFETY appears on the dot matrix display and the DSC indicator illuminates.
2. Press the SQ UP/DOWN key. The message URGENCY now appears on the dot matrix display.
3. Make your selection between SAFETY or URGENCY and press the ENT key to submit. The prompt RECONFIRM is displayed.
4. Press the ENT key to confirm. A prompt appears on the display, instructing you to press the PTT key.
5. Press PTT to transmit.

The All Ships Call is made on Channel 70. After the All Ships Call is sent, the radio automatically switches to channel 16.

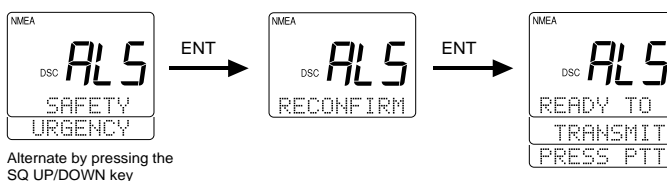

4.4.16.7 Receiving an All Ships Call

When an All Ships Call is received, an alert is sounded. The LCD displays the type of All Ships call being received, along with the sender's MMSI number, and a prompt to press ENT to accept or CLR to log the call. The alert and the displayed message continue until either ENT or CLR is pressed. If ENT is pressed, the radio switches to Channel 16 and the contents of the communication are stored in the log. If CLR is pressed, the radio reverts to the mode before receiving the All Ships Call and the contents are stored in the log.

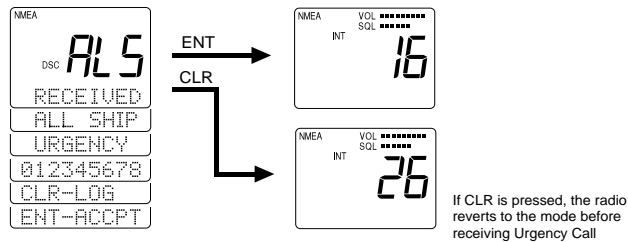

4.4.16.8 Transmitting a Distress Call

A Distress Call allows you to send out a digital “packet” of data at high power that includes your position, time, and MMSI number. All ships and stations outfitted with the correct type of DSC equipment will be able to pinpoint your position and either relay the information or respond directly. Using the Distress key overrides all other functions.

Two types of Distress Calls can be made: one that specifies the type of distress and one that does not.

Unspecified Distress Call

To make a Distress Call without specifying type of distress:

1. Open the door labeled DISTRESS on the back of the handset and press and hold the DISTRESS key. After one second, **dSr** flashes on the 7-segment display and the DSC indicator appears. On the dot matrix display, countdown message appears prompting you to hold the DISTRESS key for 4 more seconds.

- Continue to hold the DISTRESS key for the duration of the countdown. An alert tone is sounded at one-second intervals.

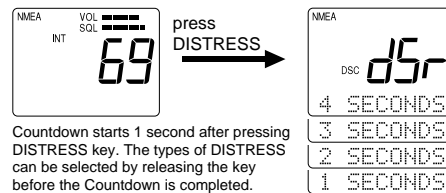

Note: If you fail to hold the key for the full 5 seconds, the DISTRESS call is cancelled.

- After the countdown has completed, the message RELEASE appears on the dot matrix display. Release the DISTRESS key.

The unit switches to channel 16, displays the message AWAIT ACK, and monitors channel 70 for an acknowledgment.

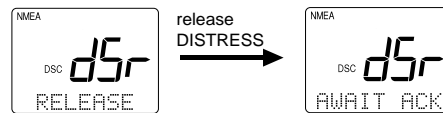

The unit retransmits the DISTRESS call at random intervals of 3.5 to 4.5 minutes, until a response is received or the call is manually cancelled.

To exit the Distress mode, press the CLR key and hold for 3 seconds. The unit reverts to the state it was in before the call was initiated.

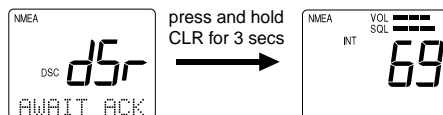

When a response is received, the DSC indicator flashes and the DSC Distress alert is sounded. The LCD scrolls a message that the DISTRESS has been acknowledged, along with the sending station's MMSI number or nickname. The message and alert are repeated until the CLR key is pressed.

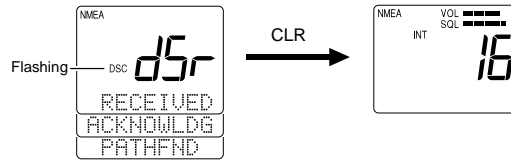

When the CLR key is pressed, the unit exits the DSC mode and continues monitoring Channel 16 on high power.

Regardless of the handset state, the DSC Distress alert is sounded at maximum volume on the external speaker, even if the volume knob has been rotated all the way OFF.

You can mute the alert tone by pressing the CLR key for one second. Pressing CLR only turns off the alert sound; it does not interrupt the Distress call.

Specified Distress Call

You can assign one of eleven distress types to the call to provide the potential rescuing station additional information if time and circumstances permit. The Nature of the distress call can be selected using the DISTRESS key as outlined below or in the system MENU as outlined in section 4.5.3.1. Below are the messages and their meanings:

Message	Meaning	Message	Meaning
FIRE	fire	ADRIFT	drifting
FLOODNG	flooding	UNDESIG	undesignated
COLLISN	collision	ABNDSHP	abandoning ship
AGROUND	run aground	PIRACY	piracy
LISTING	listing	MANONBD	man overboard
SINKING	sinking		

To make a Distress Call specifying the type of distress:

1. Open the door labeled DISTRESS on the back of the handset and press and release the DISTRESS key on the back of the handset. **dSr** appears on the 7-segment display and the DSC indicator illuminates. On the dot matrix display, the message FIRE appears.

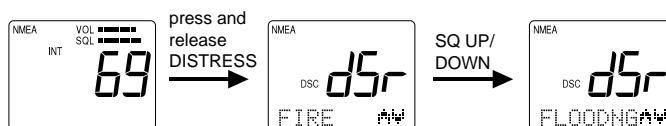

2. If FIRE is the message you wish to attach, press the ENT key.

OR

If FIRE is not the message you wish to attach, scroll through the list with the SQ UP/DOWN keys. When the appropriate message is displayed, press the ENT key.

On the dot matrix display, appears the distress type plus a message prompting you to press and hold the DISTRESS key.

3. To send the distress signal, press and hold the DISTRESS key. After one second, **dSr** flashes and a countdown message appears on the dot matrix display, prompting you to hold the DISTRESS key for 4 more seconds.

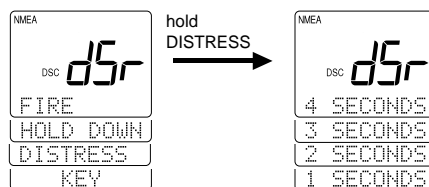

4. Continue to hold the DISTRESS key for the duration of the countdown. A tone sounds every second.

Note: If you fail to hold the key for the full 5 seconds, the DISTRESS call is cancelled.

After the 5 seconds have elapsed, the message RELEASE appears, prompting you to release the key.

5. When this prompt appears, release the DISTRESS key. The unit is switched to Channel 16, displays the message AWAIT ACK, and monitors channel 70 for an acknowledgment.



dSr stops flashing and the distress alarm sounds continuously. The unit retransmits the DISTRESS call at random intervals of 3.5 to 4.5 minutes, until a response is received or the call is manually cancelled.

Note: When a Distress Call is sent, the unit emits a *VERY LOUD* distress alarm tone. To mute the alarm without interrupting the Distress Call, press and release CLR. The radio will remain in DSC mode.

To exit the Distress mode, press the CLR key and hold for 3 seconds. The unit reverts to the state it was in before the call was initiated.

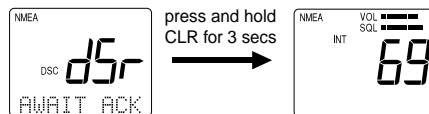

When a response is received, the DSC indicator flashes and the DSC Distress alert is sounded. The LCD scrolls a message that the DISTRESS has been acknowledged, along with the sending station's MMSI number. The message and alert are repeated until the CLR key is pressed.

When the CLR key is pressed, the unit exits the DSC mode continues monitoring Channel 16 on high power. Regardless of the handset state, the DSC Distress alert is sounded at maximum volume on the external speaker.

Note: If a Distress Call is transmitted in error, you should notify other vessels that no real emergency exists. On Channel 16, announce your name, the vessel's name, and your MMSI number then state that the Distress call was sent by accident and should be disregarded.

4.4.16.9 Receiving a Distress Call

When a Distress call is received, the DSC indicator flashes, **dSr** appears on the 7-segment display, and the DSC Distress alert is sounded. On the dot matrix display are scrolled RECEIVED, DISTRESS, the type of distress, the MMSI number, the transmitting time, the latitude, and longitude of the transmitting station.

The DSC Distress Alarm and displayed message continue until either ENT or CLR are pressed. Pressing ENT stores the contents of the call in the log and switches the radio to Channel 16. Pressing CLR also logs the call but then reverts the radio to the mode before receiving the Distress call.

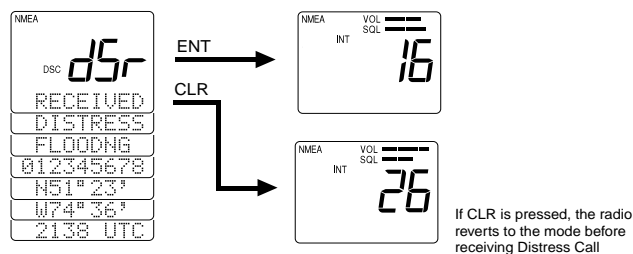

4.4.16.10 Receiving a Distress Relay Call

Sometimes a ship's distress call can be relayed from another ship or a shore station. The RAY215 can only receive a Relayed Distress call that has been addressed to All Ships.

When a Relayed Distress call is received, the DSC indicator flashes, **dSr** appears on the 7-segment display, and the DSC Distress alert is sounded. On the dot matrix display are scrolled RECEIVED, RELAY, the MMSI number of the station making the call, DISTRESS, the type of distress, the MMSI number of the ship in distress, the latitude and longitude of that ship, and the time of transmission.

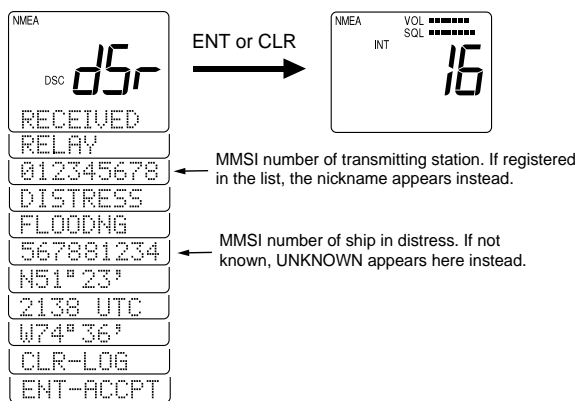

The displayed message continues until either ENT or CLR is pressed. At that time, the radio switches to Channel 16 in high power and the contents of the communication are stored in the Log File.

4.4.16.11 Using the DSC Log

The RAY215 maintains 3 separate logs for storing information about sent and received DSC calls. The logs are divided by type:

- Individual, All Ships, and Group Calls
- Distress Calls
- Relay Distress Calls

Each log can store up to 10 calls. If more than ten DSC calls of a particular type are logged, the oldest one is deleted as the new one comes in.

To view a log:

1. Press FUNC followed by LOG/CLR to enter DSC Log mode. **LoG** appears on the seven segment display and the log type appears on the dot matrix display.
2. Press the SQ UP/DOWN keys to scroll through the available logs:
DISTR for Distress calls
I/A/G for Individual/All Ships/and Group Calls
RELAY for Relay Distress Calls
3. When the desired log appears, press ENT to accept. The log number appears next to the log type, beginning with 0, the latest entry.
4. Press the SQ UP/DOWN keys to scroll through the entry numbers 0-9 for the particular log. After one second of displaying the log entry number, the log data for that entry begins scrolling across the dot matrix display, containing the following information:
 - Type of call
 - MMSI number
 - Nature of the call (Routine, Safety, or Urgency), if applicable
 - CLR-EXIT
 - ENT-DELETEIf no call exists for a particular log entry number, the data appears as all dashes (-).
5. Press the CLR key to delete the log entry from memory or press CLR to exit DSC Log mode without making changes. If an entry is deleted, the next older entry assumes the deleted entry's number. For example, if log 1 is deleted, log 2 becomes log 1, log 3 becomes log 2, and so on.

4.5 Menu Operation

The menu operation is used for making various settings and confirming the current state. The operation is roughly divided in three functions as follows:

Function	Purpose
1. NAVSTA	Indicates the information input from NMEA.
2. DSC	To register/modify various settings related to DSC.
3. SETTING	To program the MMSI number.

4.5.1 Selecting the Menu Operation

To initiate the Menu function:

1. Press the FUNC key followed by the MENU key. **Mn** appears on the 7-segment display and NAVSTAT is shown on the dot matrix display.
2. To scroll through these first level menu items, press the SQ UP/DOWN key. The indicators alternate between NAVSTAT, DSC, and SETTING.
3. Select the desired operation and press the ENT key to enter that particular menu item.

To exit the Menu operation, press and hold the CLR key for 3 seconds.

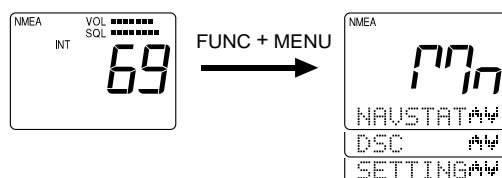

4.5.2 NAVSTAT Operation

This operation indicates on the LCD display the position information that has been input via NMEA or has been manually input using the LL/ENT function as outlined in section 4.5.3.2.

To view current position information:

1. Press the FUNC key followed by the MENU key to initiate the Menu operation.
2. Select NAVSTAT and press the ENT key. The following five items are automatically displayed at 3-second intervals in the following order:
 1. Latitude
 2. Longitude
 3. UTC Time
 4. UTC Date (Y/M/D)
 5. Position source (GPS, DIFF GPS, NO GPS)

This data is for viewing only and can not be altered.

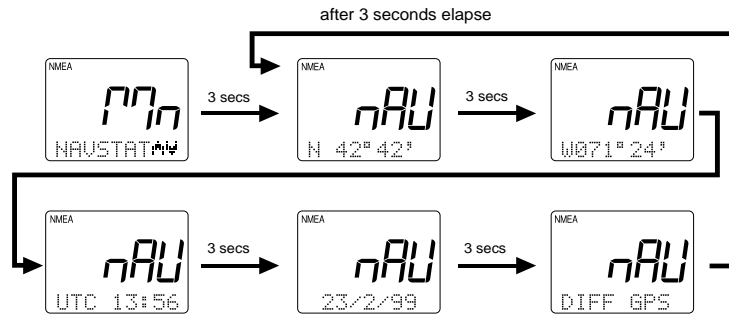

To return to the main menu screen, again press FUNC followed by MENU. To exit the Menu operation, press and hold the CLR key for 3 seconds.

4.5.3 DSC Operation

DSC operation includes the manual entry of latitude/longitude, listing of other ship's MMSI numbers for ship-to-ship and ship-to-shore communications, and listing of Group MMSI number.

To initiate the DSC operation:

1. Press the FUNC key followed by the MENU key to initiate the Menu operation.
2. Select DSC and press the ENT key. The 7-segment display shows **dSC** and the dot matrix display shows L/L ENT.

The DSC Main Menu is made up of NATURE, L/L ENT, PHNBOOK, and GROUP submenus.

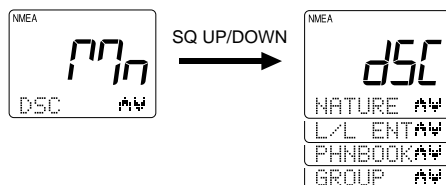

3. Press the SQ UP/DOWN key until the desired operation is displayed:

NATURE	Select type of Distress Call
L/L ENT	Manual entry of latitude/longitude
PHNBOOK	Listing of MMSI number
GROUP	Listing of Group MMSI number

4. Press the ENT key to submit.

4.5.3.1 Selecting Distress Call Type (NATURE)

This menu item is used to select the nature of a distress call before the call is sent. The selected information will be sent along with the distress call.

To select the nature of the distress that will be included with the call:

1. As described in section 4.5.3 DSC Operation above, select the DSC operation NATURE.
2. Press the ENT key to initiate the process. The 7-segment display shows **nAt** and the dot matrix display shows FIRE.
3. Use the SQ UP/DOWN key to select the type of distress.

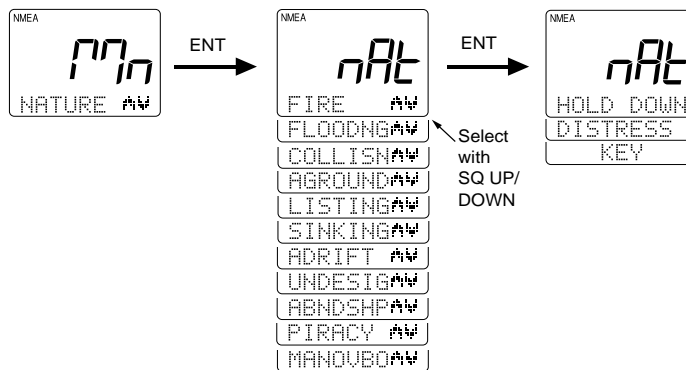

4. After selecting the desired distress type, press ENT. You are prompted to press the DISTRESS key.
5. To send the distress call at this time, press and hold the DISTRESS key. Follow the instructions on the display or the steps described in section 4.4.16.8.
6. To cancel the distress call, press and hold CLR for 3 seconds.

4.5.3.2 Manual Entry of Latitude/Longitude (L/L ENT)

This operation is used to manually enter the latitude/longitude and UTC time when normal NMEA input of the position information is not available. The radio will sound a 5-second-long alert tone every four hours to remind you to update your position.

- As described in section 4.5.3 DSC Operation above, select the DSC operation L/L ENT. The 7-segment display shows **LL**, while the dot matrix display shows the latest latitude data.
- Press one of the following keys to initiate the corresponding operation:

Keys	Action
0 - 9 keys	Changes the flashing numeric value (see step 3), then advances to the next digit's place.
ENT key	Advances from Latitude, to Longitude, to UTC.
CLR key	Returns to the previous subject item.
SQ UP/ DOWN key	For Latitude, alternates between N and S. For Longitude, alternates between E and W. For UTC, no effect.

- The subject items can be changed in the following order. Numeric values that can be changed are flashing:
 - Degrees of lat at ten's place
 - Degrees of lat at unit's place
 - Minutes of lat at ten's place
 - Minutes of lat at unit's place
 - Degrees of lon at hundred's place
 - Degrees of lon at ten's place
 - Degrees of lon at unit's place
 - Minutes of lon at ten's place
 - Minutes of lon at unit's place
 - Hours of UTC at ten's place
 - Hours of UTC at unit's place
 - Minutes of UTC at ten's place
 - Minutes of UTC at unit's place
- After changing the subject item, the display scrolls from latitude to longitude to UTC. To submit the change of the position data as shown in the display, press the ENT key. The unit exits Menu mode and returns to normal operation.

To exit the Menu operation, press and hold the CLR key for 3 seconds. The following illustration shows an example of the operation:

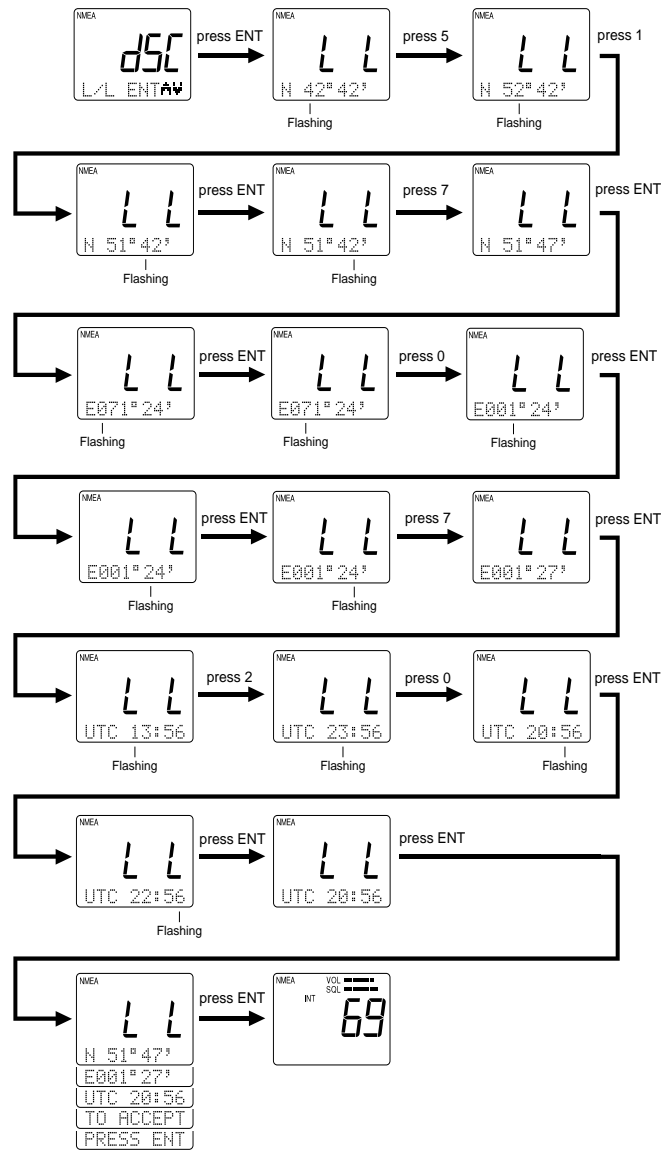

4.5.3.3 Modifying the MMSI Number List (PHNBOOK)

This operation is used to modify the “phonebook” lists of MMSI numbers used for DSC Individual Calls. Two lists are available: one for Ship stations and one for Shore stations. Each list allows you to register the MMSI number and nickname for up to 20 Ship and 20 Shore stations.

Note: *The 20 Ship stations and 20 Shore stations in this phonebook are separate from the 10 phonebook entries stored in the base station using the fist microphone (see section 3.3.17.2). All 50 entries are available for you to use.*

1. As described in section 4.5.3 DSC Operation above, select the DSC operation PHNBOOK.
2. Press the ENT key to initiate the process. The 7-segment display shows **Phb** and the dot matrix display shows SHIP.

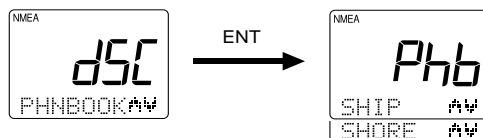

3. Use the SQ UP/DOWN key to select between SHIP or SHORE.
4. Press the ENT key to turn to submit your selection.

Modifying the List of Ship Stations

In this operation, a ship is registered (added) to or deleted from the phonebook list for ship stations.

1. When SHIP is displayed, press the ENT key. The 7-segment display shows SHP, while on the dot matrix display shows ENTRY.
2. The list can hold a maximum of 20 entries. If a list is already full or if the list becomes full during this process, the indicator PHNBOOK IS FULL is displayed.
3. To delete an item from the list, use the SQ UP/DOWN key to select DELETE and press the ENT key. If no station has yet been registered, the message PHNBOOK IS EMPTY is displayed.

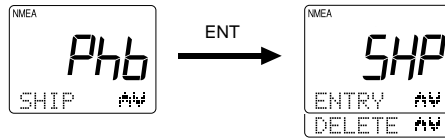

Note: Pressing and holding the CLR key for 3 seconds during either ENTRY or DELETE returns operation to the mode before the Menu operation began.

Adding Ship Stations to the List

To add to the phonebook list for ship stations, input the MMSI number and nickname of the station.

1. To enter the MMSI number, press the corresponding numeric keys (0 through 9). The currently selected location is indicated by a flashing “-” character. Pressing a numeric key enters that value then advances to the next digit's place. To go back by 1 digit, press the CLR key.
2. To enter the nickname, use the numeric keys (0 through 9) to input the associated alpha or numeric value (refer to section 4.2 Controls and LCD Display). The currently selected location is indicated by the flashing “-” character. After inputting the desired letter or numeral, press the ENT key to submit the entry and proceed to the next place.

To go back by 1 digit, press the CLR key.

If no nickname is to be registered, press the ENT key for all characters so that they all display a “-”.

3. When the message CONT? Y appears, press the ENT key to submit.

Note: The 0 key will enter only the numeral “0”, while the 1 key will alternately enter “1” and “space”. The 0 and 1 keys do not have associated alpha characters.

Modifying the List of Shore Stations

In this operation, a shore (coast) station is registered (added) to or deleted from the phonebook list.

1. When SHORE is displayed, press the ENT key. **SHO** appears on the 7-segment display, while on the dot matrix display shows ENTRY.
2. The ENTRY selection is used to register (add) an item to the list. Press the ENT key to accept.

The list can hold a maximum of 20 entries. If a list is already full or if the list becomes full during this process, the indicator PHNBOOK IS FULL is displayed.

3. To delete an item from the list, use the SQ UP/DOWN key to select DELETE and press the ENT key. If no station has yet been registered, the message PHNBOOK IS EMPTY is displayed.

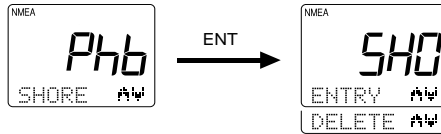

Note: Pressing and holding the CLR key for 3 seconds during either ENTRY or DELETE returns operation to the mode before the Menu operation began.

Adding Shore Stations to the List

To add to the phonebook list for shore stations, input the MMSI number and nickname of the station.

1. To enter the MMSI number, press the corresponding numeric keys (0 through 9). The currently selected location is indicated by a flashing “_” character. Pressing a numeric key enters that value then advances to the next digit's place. To go back by 1 digit, press the CLR key.
2. To enter the nickname, use the numeric keys (0 through 9) to input their associated alpha or numeric value (refer to section 4.2 Controls and LCD Display). The currently selected location is indicated by a flashing “_” character. After inputting the desired letter or numeral, press the ENT key to submit the entry and proceed to the next place. To go back by 1 digit, press the CLR key.

- When the message CONT? Y appears, press the ENT key to submit the registration.

If no nickname is to be registered, press the ENT key for all characters so that they all display a “-”.

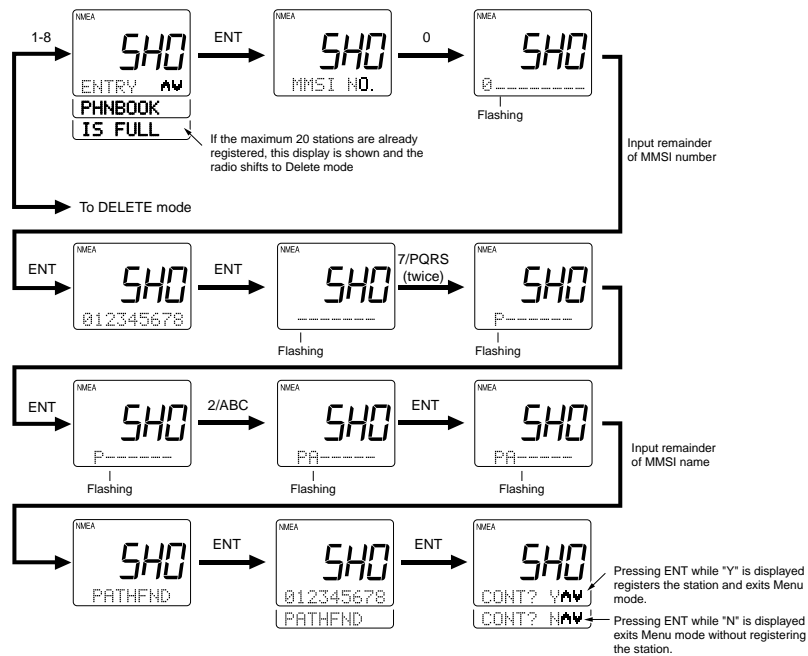

Note: The 0 key will enter only the numeral “0”, while the 1 key will alternately enter “1” and “space”. The 0 and 1 keys do not have associated alpha characters.

Deleting Shore Stations from the List

When the shore station phonebook is selected, the oldest MMSI number or nickname flashes on the dot matrix display.

1. Press the SQ UP/DOWN key to scroll through the registered stations until the station to be deleted is displayed.
2. Press the ENT key; the message DEL? Y is displayed.
3. Press the ENT key to process the deletion and exit the Menu operation.

To exit without deleting, press the SQ UP/DOWN key until DEL? N is displayed. If the list has no stations entered, the message PHNBOOK IS EMPTY HOLD DOWN CLR KEY is displayed. Press and hold the CLR key for 3 seconds to exit Menu mode.

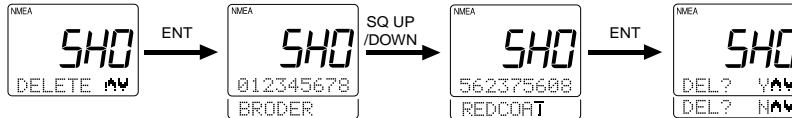

4.5.3.4 Modifying the MMSI Group Number (GROUP)

This operation modifies the MMSI number to be used in receiving a Group Digital Selective Call.

1. As described in section 4.5.3 DSC Operation above, select the DSC operation GROUP.
2. Press the ENT key to initiate the process. The 7-segment display shows GrP and the dot matrix display shows ENTRY.
3. Use the SQ UP/DOWN key to alternate between ENTRY or DELETE.
4. Press the ENT key to turn to submit the desired selection.

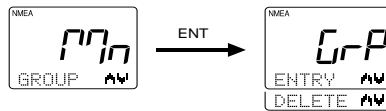

Entering a Group MMSI Number

To enter a Group MMSI number, select ENTRY then press the ENT key. Use the numeric keys (0 through 9) to input desired group number. The currently selected location is indicated by a flashing “-” character. Pressing a numeric key enters that value then advances to the next place. To go back by 1 digit, press the CLR key.

After the last position has been filled, the message CONT? Y appears. Press ENT to register the group and exit the Menu operation. To exit without registering, press SQ UP/DOWN until DEL? N is displayed. Press the ENT key and operation returns to mode before the Menu operation began.

Note: By default, the first digit of the Group MMSI is always “0”.

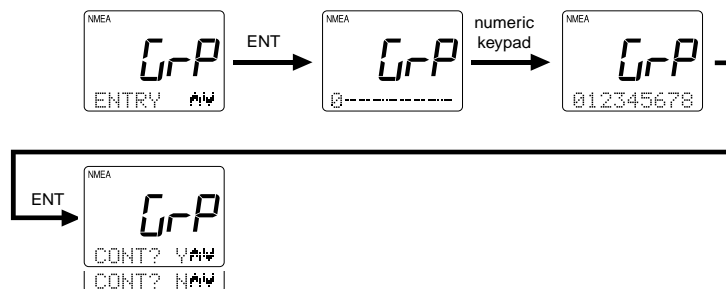

Deleting a Group MMSI Number

Use the SQ UP/DOWN key to select DELETE. To delete the contents indicated, press the ENT key and the message DEL? Y is displayed. Press the ENT key to process the deletion and exit the Menu operation. To exit without deleting, press the SQ UP/DOWN key until DEL? N is displayed. Press the ENT key and operation returns to the mode before the Menu operation began.

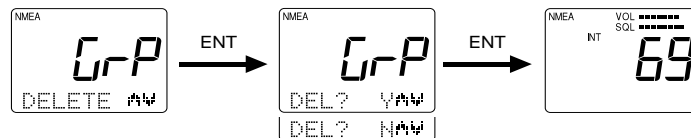

4.5.4 Setting the MMSI Number

This operation stores the MMSI number required for DSC communications, including distress calls. You can request an MMSI number when you apply for a radio license. If your vessel does not require a license, you may obtain an MMSI by contacting either BoatUS (www.boatus.com) or MariTEL (www.maritelusa.com).

Notes:

- *This is a one time operation. Once the MMSI number has been programmed, you will not be able to change it.*
- *Until the MMSI number is programmed, all DSC functionality is disabled. Pressing the INDV, ALL SHIP, and DISTRESS buttons will only sound an error alert.*

1. Press the FUNC key followed by the MENU key to initiate the Menu mode. **Mn** appears on the 7-segment display and NAVSTAT appears on the dot matrix display.
2. Press the SQ UP/DOWN key to select SETTING.
3. Press the ENT key. The message SET appears on the 7-segment display and MY MMSI appears on the dot matrix display.

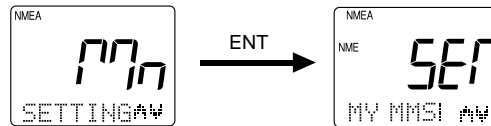

4. Press the ENT key to submit. **MS** appears on the 7-segment display. If the MMSI number has already been saved to the unit, the dot matrix display scrolls the programmed MMSI number.

If the MMSI number has not yet been saved to the unit, the dot matrix display scrolls PLEASE PROGRAM MMSI NO.

5. Press ENT. Nine underscore characters appear, which are placeholders for the 9 digits of the MMSI number. The first character place to be input is flashing.

Pressing the following keys initiate the corresponding operation:

Keys	Action
0 - 9 keys	Changes the flashing numeric value, then advances to the next digit's place.
ENT key	Advances the (flashing) subject item to the next one without changing the numeric value. Advances to the next screen after entering the last (ninth) digit.
CLR key	Returns to the previous subject item. Pressing and holding for 3 seconds exits the operation and returns to the mode before the operation began.

6. Input your MMSI number using the numeric keypad.
7. Press the ENT key. The message ENT - ACCEPT, CLR - EXIT scrolls across the display.
8. Press the ENT key to submit the number. The message ENTER MMSI NO. AGAIN is displayed.
9. Press ENT. The nine underscore placeholders appear once more.
10. Again input the MMSI number with the numeric keypad.
11. Press ENT to submit. If the second MMSI number you input matches the first, the message ENT - ACCEPT, CLR - EXIT is again displayed.

Note: *If the two MMSI numbers don't match, the message MMSI NO. NOT MATCH PRESS ENT scrolls across the display. Press ENT to exit the Menu mode and try again from step 1.*

12. Press ENT to verify. The message ENT - STORE, CLR - EXIT is displayed.
13. Press ENT one last time to register the MMSI number in memory. Operation returns to the mode before the Menu mode began.

To exit without making changes at any time, press and hold CLR for 3 seconds.

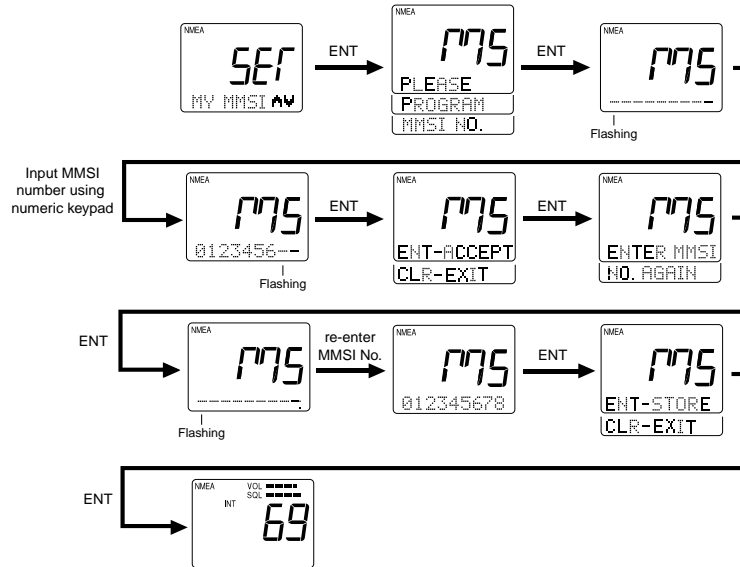

Section 5 Maintenance

5.1 How to Contact Raymarine

The RAY215 is designed to provide long periods of trouble-free operation. It is recognized, however, that environmental and other factors may result in a need for occasional service.

In the US

Technical Support **1-800-539-5539 ext. 2444, or**
1-603-881-5200 ext. 2444

You can reach our Technical Support Department Monday to Friday 4:00 AM to 6:00 PM Eastern Standard Time. Our Technical Support Specialists are available to answer installation, operation, and troubleshooting questions about your Raymarine unit.

Accessories and Parts **1-800-539-5539 ext. 2333, or**
1-603-881-5200 ext. 2333

Many Raymarine accessory items and parts are available through your authorized Raymarine dealer. However if you are in need of an item not available through your retailer feel free to contact our Customer Service department Monday to Friday 8:15 AM to 5:00 PM Eastern Standard Time. If you are uncertain about what item to choose for your Raymarine unit please contact our Technical Support Department Prior to placing your order at 1-800-539-5539 ext. 2065.

In the unlikely event your Raymarine unit should develop a problem please contact the Raymarine dealer from where the unit was purchased. Your Raymarine dealer is best equipped to handle your service needs.

Service may also be obtained by returning your unit to Raymarine's Product Repair Center at the address below.

Raymarine, Inc.
Product Repair Center
22 Cotton Road, Unit D
Nashua, NH 03063-4219

In Europe

In Europe, Raymarine support, service and accessories may be obtained from your authorized dealer, or contact:

Raymarine Limited
Anchorage Park
Portsmouth, Hampshire
England PO3 5TD
Tel +44 (0) 23 9269 3611
Fax +44 (0) 23 9269 4642

Technical Support Tel +44 (0) 23 9269 3611
Fax +44 (0) 23 9269 4642

The Technical Services Department handles inquiries concerning installation, operation, fault diagnosis and repair.

Accessories and Parts

Raymarine accessory items and parts are available through your authorized Raymarine dealer. Please refer to the lists of component part numbers and optional accessories in Section 2.2.1 of this handbook and have the Raymarine part number ready when speaking with your dealer. If you are uncertain about what item to choose for your Raymarine unit, please contact our Customer Services Department prior to placing your order.

Worldwide Support

Please contact the authorized distributor in your country. A list of worldwide distributors is supplied with your unit and on the Raymarine website.

On the Internet

You can also reach us on the Raymarine World Wide Web site:

www.raymarine.com

Navigate to the **Customer Support** page, which provides links for:

- Finding Factory Service locations and Authorized Dealers near you
- Accessing handbooks in Adobe Acrobat format
- Searching questions and answers in our solution database by product, category, keywords, or phrases
- Submitting a question to our technical support staff, who reply to you by e-mail
- Logging in to check the status of your questions, modify your answer update notifications, or update your personal profile

Questions can be sent directly to our Technical Support Department on the Customer Support page by clicking **Ask Raymarine**.

5.2 Preventative Maintenance

The RAY215 has been constructed to be virtually maintenance free. Your attention to a few basic points should assure many years of service.

1. Although the unit is waterproof, always keep the unit as dry as possible.
2. Clean the exterior of the unit with a tissue or soft non-abrasive cloth.

CAUTION

Do not use solvents or other chemicals for cleaning this equipment.

3. Inspect the radio case and antenna for any physical damage.

5.3 Specifications

5.3.1 Transmitter

Channels	All available US, International and Canada VHF Marine band
Frequency Stability	+/- 10PPM (+/- 0.001%) (-20 °C to +50 °C)
Frequency Range	156.025 to 157.425MHz
Channel Spacing	25 kHz Increments
Power Output	25 Watts switchable to 1 Watt into 50 Ohms at 13.6VDC
Modulation	Frequency modulated 16F3
Modulation Audio Response	Shall not vary +1/-3 dB from true 6 dB pre-emphasis from 300 to 2500Hz, reference 1000Hz. Audio frequencies 3-20 kHz shall be attenuated (at 1 kHz by 60 log f/3 dB. Above 20kHz by 50dB)
FMHum&Noiselevel	Less than -40dB below audio
Audio Distortion	Less than 10% at 1kHz for 3kHz deviation
Spurious & Harmonic	Attenuated at least 43+10log Po (below rated radiated carrier Emissions power) per FCC Rules Part 2 & 80
Antenna Impedance	50 Ohm
Transmitter Protection	Open and short antenna protection circuit for 10 minute transmission

5.3.2 Receiver

Channels	All available US, International, Canadian VHF Marine Band
Frequency Range	156.025 to 163.275 MHz in 25 kHz increments
Frequency Stability	+/- 10 PPM (+/- 0.001%) from -20 °C to +50 °C
Usable Sensitivity	0.23µV @ 12dB SINAD
Threshold	1.0µ full squelch
Adjacent Channel Rejection	70dB
Spurious Image Rejection	70dB
Intermodulation Rejection	70dB
Audio Output	2 Watts or more at 10% or less distortion into 4 Ohm load (internal)
Hum & Noise in Audio	Less than -40dB

5.3.3 Operating Requirement

Input Voltage	13.6 VDC +/- 15% (11.6 to 15.6 VDC)
Current Required	Typical 6 amp at 25 Watts
Transmit	Typical 2 amp at 1 Watt
Operating Temperature	-20 °C to +50 °C
Duty Cycle	Continuous, 80% receive, 20% transmit (max 10 min, @25 °C)
Humidity	100% at 50 °C for 8 hours

5.3.4 Radio Dimensions

Base Station Transceiver

Height	3.15 inches (80 mm)
Width	7.68 inches (195 mm)
Depth	6.70 inches (170 mm)
Weight	Approx. 2.2 lbs (1.0 kg)

Fist Microphone

Height	3.54 inches (90 mm)
Width	2.28 inches (53 mm)
Depth	1.65 inches (42 mm)
Weight	Approx. 0.30 lbs (138 g)

Optional Full Function Handset (FFHS)

Height	6.81 inches (173 mm)
Width	2.25 inches (57 mm)
Depth	1.1 inches (28 mm)
Weight	Approx. 0.30 lbs (138 g)

Optional FFHS Cradle

Height	1.97 inches (50 mm)
Width	2.52 inches (64 mm)
Length	4.02 inches (102.1 mm)
Weight	Approx. 0.15 lbs (70 g) (without cables)

Optional FFHS External Speaker

Height	4.48 inches (114 mm)
Width	4.33 inches (110 mm)
Depth	1.57 inches (40 mm)
Weight	Approx. 0.75 lbs (340 g)

This page intentionally left blank

5.4 Drawings

Assembly Drawing

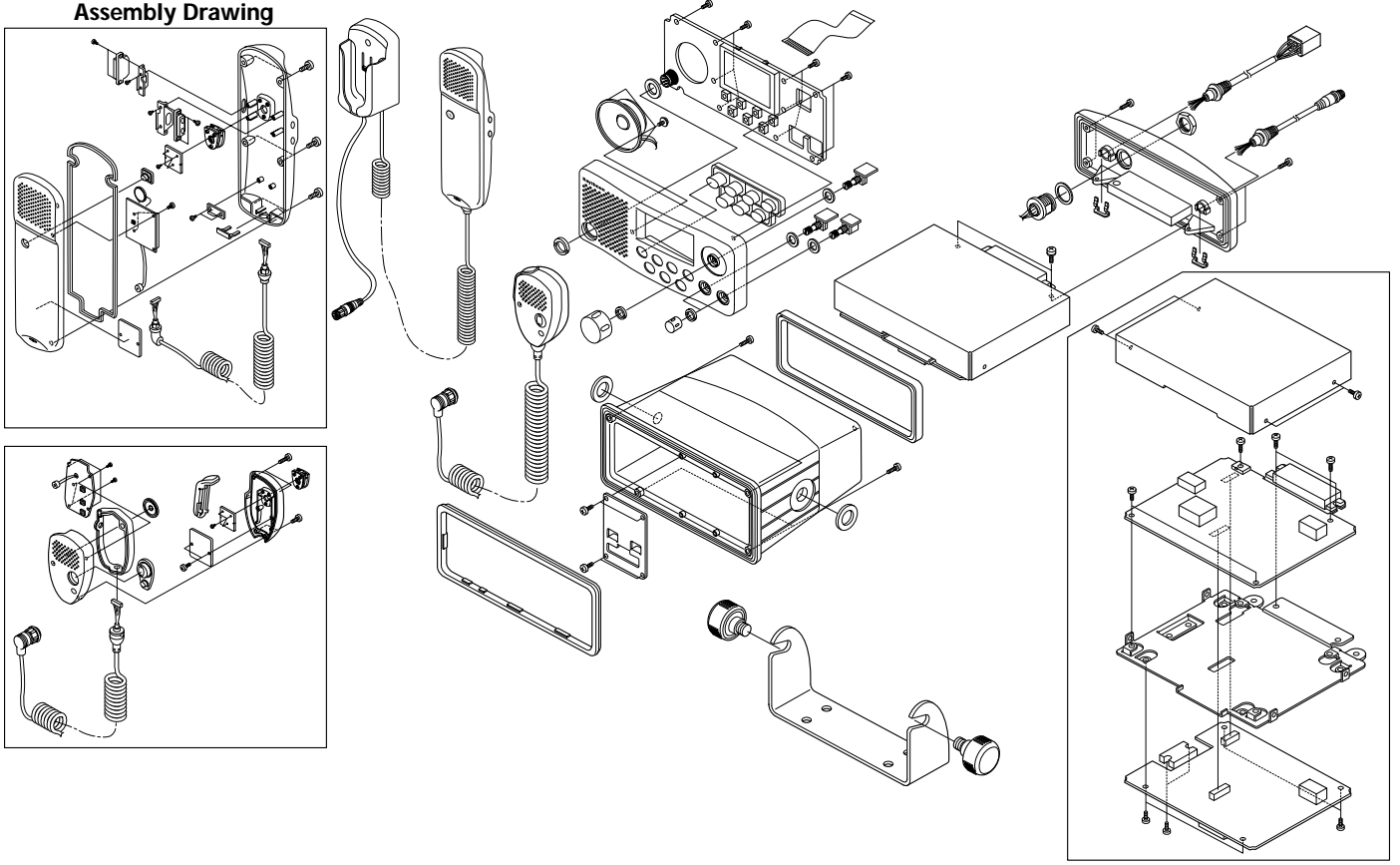

Block Diagram RF PCB

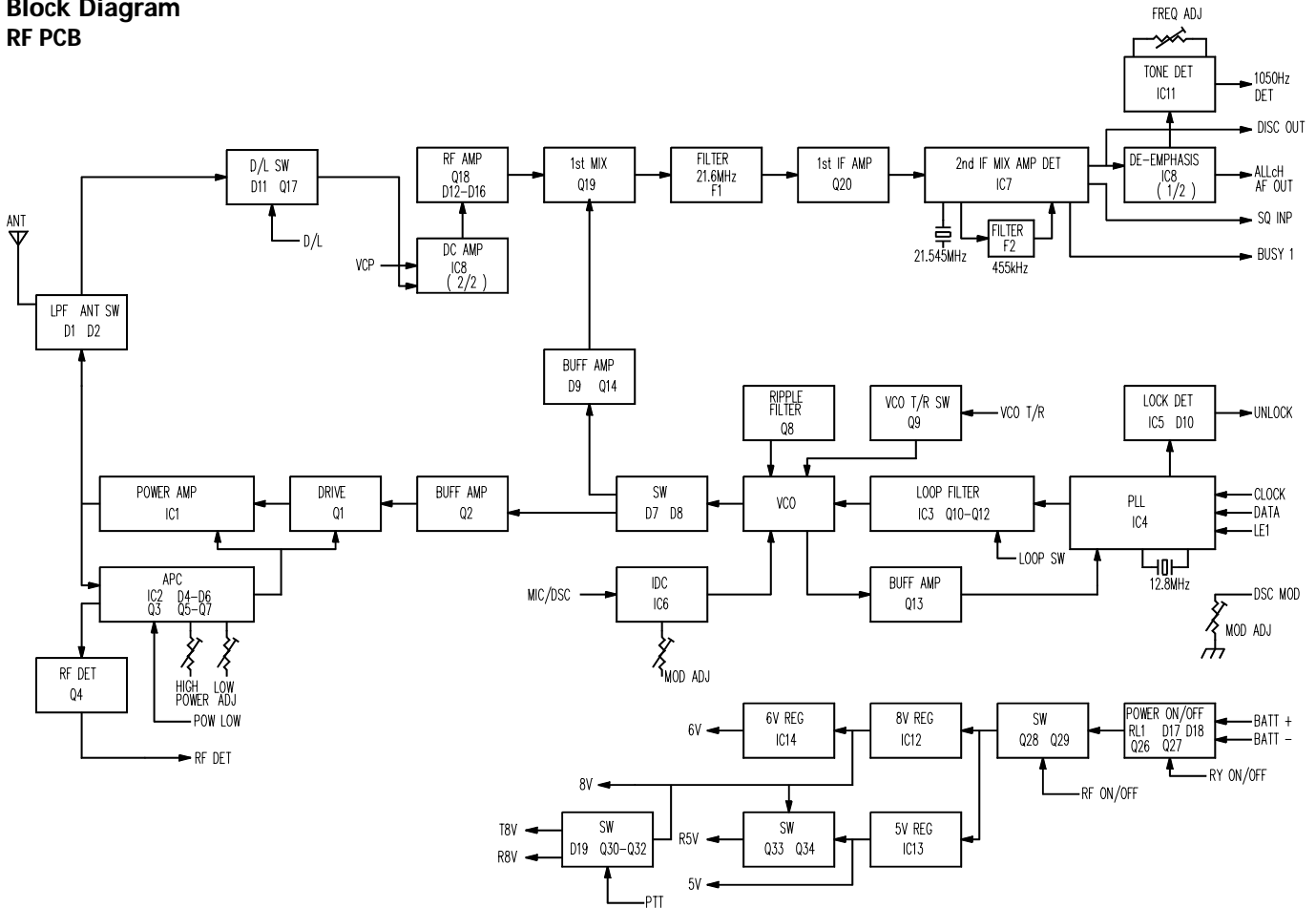

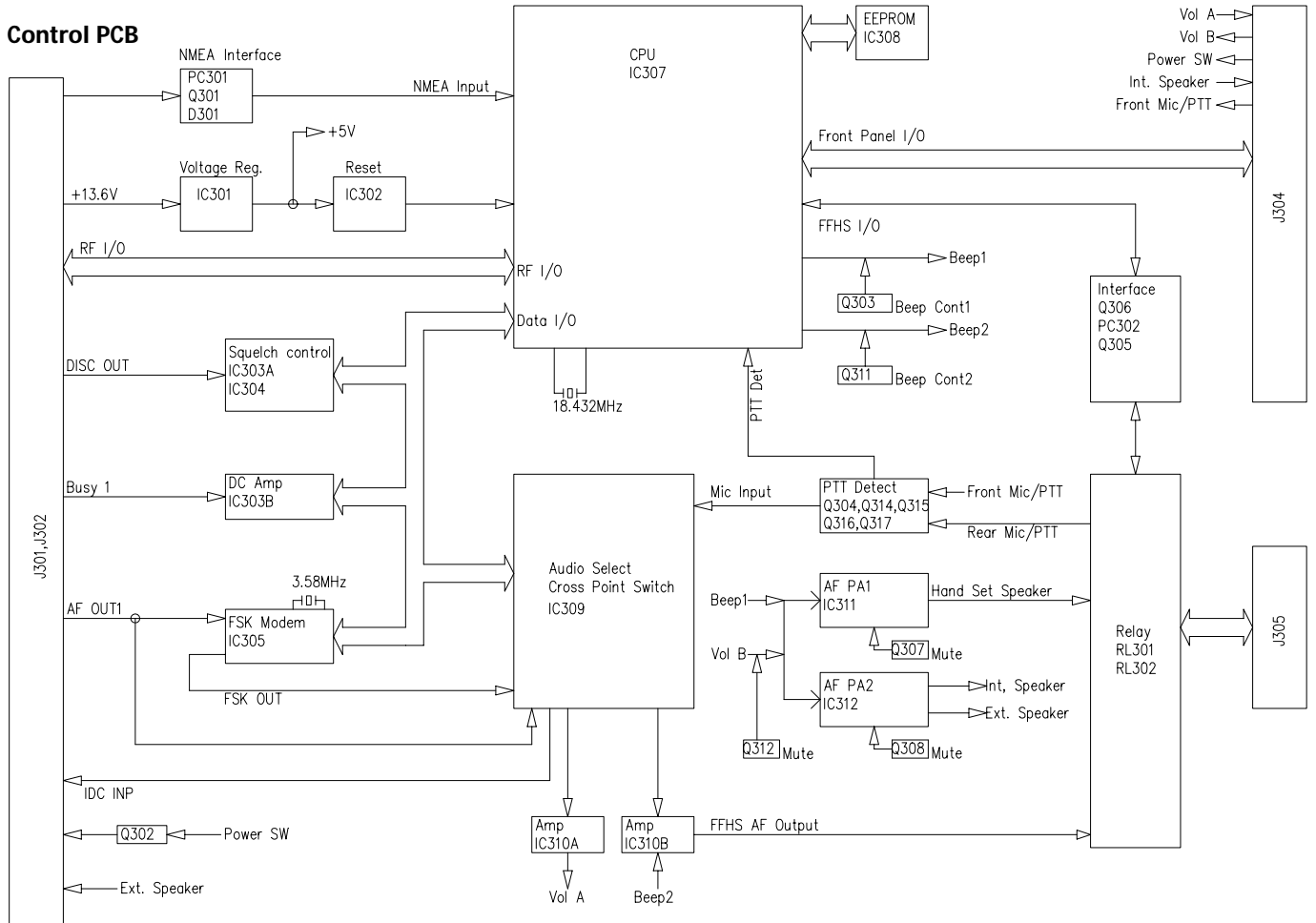

Front PCB

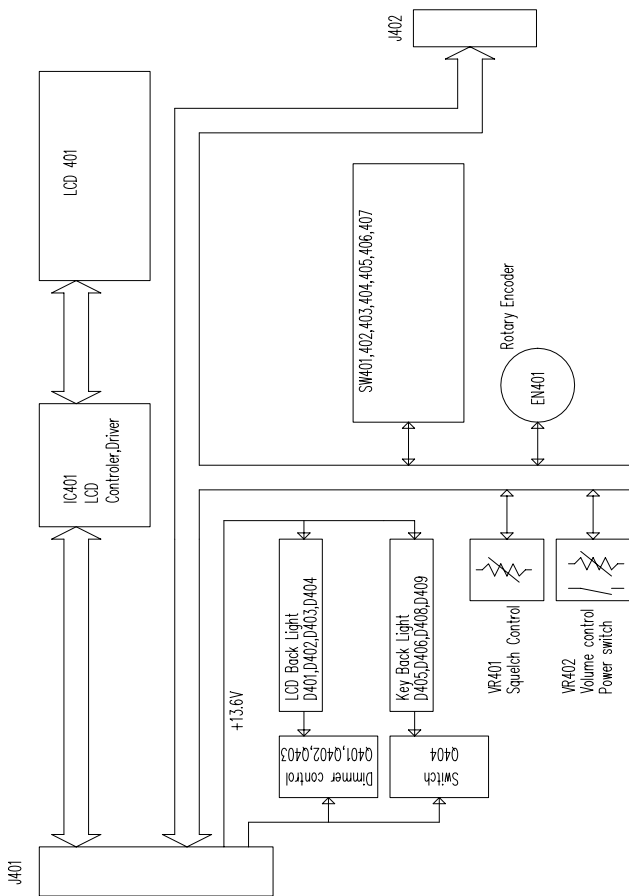

Microphone PCB

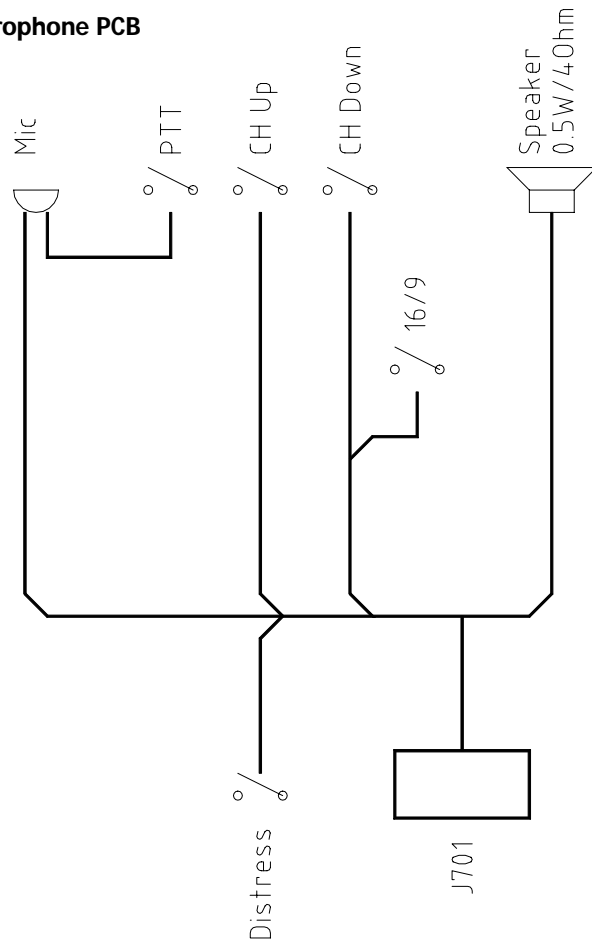

Section 6 Appendix

6.1 FCC Licensing Requirements

Raymarine radios comply with the Federal Communications Commission (FCC) requirements that regulate marine VHF radio usage for the US.

Marine VHF radio users in the US must comply with all applicable FCC rules and regulations, some of which are described here. This information was current at the time this handbook was printed. Up-to-date information, including licensing requirements, can be obtained on the FCC website at:

www.fcc.gov/wtb/marine

Official FCC forms can be obtained on the FCC website at:

www.fcc.gov/formpage.html

Station License

An FCC Ship Radio Station License and Call Sign are not required for most recreational vessels travelling in US waters. Examples of radio equipment that **do not** require a license include: marine VHF radios, any type of Emergency Position Indicating Radio Beacon (EPIRB), any type of radar, GPS or LORAN receivers, depth finders, CB radio, or amateur radio (an amateur license is required). However, you must obtain a license if: (1) you are required by law or treaty to carry a radio on your vessel; (2) your vessel travels to foreign ports; (3) you use marine radio equipment on board your vessel other than the devices listed above. Ships that use MF/HF single side-band radio, satellite communications, or telegraphy must be licensed by the FCC.

If required, you can obtain a Station License by completing FCC Form 605 (available from the FCC website). If no fees are required, mail the completed form to:

Federal Communications Commission
1270 Fairfield Road
Gettysburg, PA 17325-7245

If fees are required, send Form 605 and the required fees to:

Federal Communications Commission
Wireless Bureau Applications
P. O. Box 358130
Pittsburgh, PA 15251-5130

Operator License

An Operator License is not required to operate a VHF Marine Radio within US territorial waters. However, a license is required to operate the radio if you dock in a foreign port (including Canada and Mexico) or leave a foreign port to dock in a U.S. port. You can request a Restricted Radiotelephone Operator Permit from the FCC by filing Form 753.

Remember:

- Maintain a radio watch on Channel 16. Channel 16 is used for distress and safety purposes only.
- VHF Channel 70 is used only for Digital Selective Calling (DSC). It can not be used for general-purpose calling.
- Your VHF transceiver has a high low power switch. Use low power whenever feasible. Unnecessary high-power operations can interfere with other important communications.
- Always use your radio call sign at the beginning and end of each transmission.
- Be sure only qualified persons operate your radio. You are responsible for control of your radio. Know the rules.
- Limit calls to other vessels to 30 seconds. If you receive no reply, wait 2 minutes; then try again. Keep communications brief and avoid chit-chat.
- Never transmit false distress messages, and never use profanity on the air.

Other Reminders:

- You can obtain a station license and call sign by completing FCC Form 605 and mailing it with the required fee (if required) to the FCC.
- You need a radio operator license to operate a VHF Marine Radio only if you plan to dock in a foreign port or leave a foreign port to dock in a U.S. port.
- Your radio license is not transferable. If you sell your boat, request the FCC to cancel your station license.
- If you replace your radio, you do not need to change your license unless the new radio operates on another frequency band. If you install equipment to operate on another frequency band, apply for modification of your license.

6.2 Marine VHF Channel Usage Guide



Emergency



Calling



Monitoring

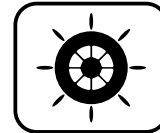

Intership Safety



U.S. Coast Guard

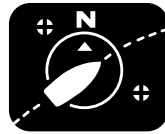

Navigation



Port Operation



Noncommercial



Commercial

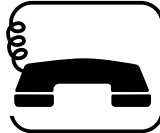

Marine Operator



State Control



Environmental



Weather



Emergency

Channel 16

If:

- Your ship is sinking, or on fire
- Someone has been lost overboard
- There exists grave and imminent danger

Use this distress procedure:

- Select Channel 16
- Say "Mayday, Mayday, Mayday."
- Give call sign and boat name
- Give location of boat
- Describe emergency
- If no answer, repeat; then try another channel

Caution

Every ship at sea is obliged to give absolute priority to radio communications relating to ships in distress - it is vital that false distress calls or messages not be broadcast.



Calling

Channel 16, 9, and Working Channel

- If - you wish to establish communications with another station
- And - you know which working channel the station is monitoring
- Then - initiate the call directly on that working channel
- If - you wish to establish communications with another station
- And - you do not know what working channel the station may be monitoring
- Then - initiate the call on channel 16. After contact is made switch to a working channel.

Note: Due to congestion on channel 16 caused by frequent hailing of other vessels, the FCC has approved channel 9 as a second hailing channel.

Avoid excessive calling and radio checks

Always monitor before transmitting
Never interrupt emergency communications

**Monitoring**

Channel 16 and Working Channel

When - your VHF station is turned on and it is not being used to exchange communications

You Must - monitor channel 16

As an operating convenience, many stations employ a second receiver so that they can monitor a working channel and channel 16 simultaneously.

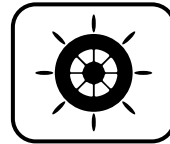
**Intership Safety**

Channel: 6

Vessels: Any

Use: Communicating navigational and weather warnings to other ships

Communicating with U.S. Coast Guard stations or other vessels during search and rescue operations

Between: Ship-to-ship only

Comments: Do not use for routine communications. This is a safety channel.



U.S. Coast Guard

Channel: 22A

Vessels: Any

Use: Working channel for exchange of communications with stations of the U.S. Coast Guard.

Between: Ship to U.S. Coast Guard ship, coast to aircraft stations

Comments: U.S. Coast Guard does not regularly monitor this channel. Establish contact on channel 16 and shift to channel 22A as directed.

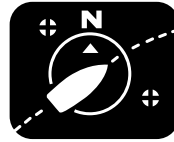

Navigation

Channel: 13

Vessels: Any

Use: Safety Communications pertaining to the maneuvering of vessels or the directing of vessel movements

Between: Ship-to ship and secondarily ship-to-coast

This is commonly called the Bridge-to-Bridge channel. Large vessels and towboats depend on this channel for their safe navigation. Railway or highway bridges which open for ship navigation often operate on this channel.

Bridge-to-Bridge stations must reduce power to one watt for routine operations.



Port Operations

Channels: 1A, 5A, 12, 14, 20A, 65A, 66A, 73, 74, 77

Vessels: Any

Use: Messages relating to the operational handling, movement and safety of vessels in or near ports, locks and waterways.

Between: Ship-to ship or ship-to-coast

Comments: Channel 77 is limited to communications to and from commercial pilots concerning the movement and docking of vessels.

Note: Channels 11, 12, 13 and 14 are used for vessels traffic service on the Great Lakes, St. Lawrence Seaway and designated major ports.

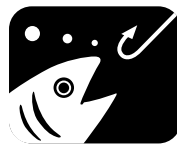

Non commercial (Boat Operations)

Channels: 9, 68, 69, 71, 72, 78A

Vessels: Recreational boats and any others not used primarily for commercial transport.

Use: Communications pertaining to the needs of the vessel (i.e., fishing, rendezvous, maneuvers, berthing, scheduling of repairs, provisioning, etc.)

Between: Ship-to-ship or ship to limited coast stations

Comments: Channel 72 may not be used for ship to coast communications. Channel 9 is shared with Commercial users.

If you regularly monitor one of these channels with a second receiver, please notify frequently-called stations of this practice. Help reduce congestion on channel 16.



Commercial

Channels: 7A, 8, 9, 10, 11, 18A, 19A, 67, 79A, 80A, 88A

Vessels: Those used primarily for commercial transport of persons or goods, or engaged in servicing other vessels

Use: Communications pertaining to the purpose for which the vessel is used

Between: Commercial transport vessels (ship-to-ship) or between commercial transport vessels and limited coast stations

Channel 8, 67 and 88A may not be used for ship-to-coast communications

Recreational boats are not permitted to use these channels



Marine Operator

Channels: 24, 25, 26, 27, 28, 84, 85, 86, 87

Vessels: Any

Use: To place a telephone call to any location in the world or to a vessel outside of your transmitting range

Between: Vessels and public coast stations

Comments: Contact the marine operator on the channel assigned to your navigating area. If unable to determine this channel, use channel 16.

Be patient. Do not interrupt calls in progress. Avoid excessive calling if the operator does not answer - give the operator a chance to reply.

**State Control**

Channel: 17

Vessels: State and local government

Use: Coordination, regulation and control of boating activities and the rendering of assistance to vessels.

Between: Ship and coast stations associated with state and local governments.

**Environmental**

Channel: 15

Vessels: Any (receive only)

Use: Broadcast of information concerning the environmental conditions in which vessels operate - weather, sea conditions, time signals, notices to mariner, hazards to navigation

Between: One-way broadcast from coast to ship stations

Note: Currently used for Class C EPIRB emergency signals.

**Weather**

Channels: WX0—WX9

Vessels: Any

Use: Continuous weather information from NOAA (National Oceanic and Atmospheric Administration)

Between: One-way broadcast from NOAA to any interested parties

Comments: Receive only. You are not permitted to transmit on these frequencies.

PHONETIC ALPHABET:

To help make call letters more clearly understood, and to assist in spelling out similar sounding or unfamiliar words, radiotelephone users employ the international phonetic alphabet.

Phonetic Alphabet:

A - ALPHA
B - BRAVO
C - CHARLIE
D - DELTA
E - ECHO
F - FOX-TROT
G - GOLF
H - HOTEL
I - INDIA
J - JULIET
K - KILO
L - LIMA
M - MIKE
N - NOVEMBER
O - OSCAR
P - PAPA
Q - QUEBEC
R - ROMEO
S - SIERRA
T - TANGO
U - UNIFORM
V - VICTOR
W - WHISKEY
X - X-RAY
Y - YANKEE
Z - ZULU

6.3 VHF Marine Channels Frequency Tables

International Mode

Note: *International VHF frequency usage varies from country to country. Ensure you are familiar with the channel requirements of the country where you are boating before using any VHF transceiver.*

International Mode				
Channel Number	Frequency (MHz)		Type of Traffic	TX Power
	TX	RX		
01	156.050	160.650	Public Correspondence (Marine Operator)	Hi, Lo
02	156.100	160.700	Public Correspondence (Marine Operator)	Hi, Lo
03	156.150	160.750	Public Correspondence (Marine Operator)	Hi, Lo
04	156.200	160.800	Public Correspondence (Marine Operator)	Hi, Lo
05	156.250	160.850	Public Correspondence (Marine Operator), Port Operations, Ship Movement	Hi, Lo
06	156.300	156.300	Intership Safety	Hi, Lo
07	156.350	160.950	Public Correspondence (Marine Operator), Port Operations, Ship Movement	Hi, Lo
08	156.400	156.400	Intership	Hi, Lo
09	156.450	156.450	Intership, Port Operations, Ship Movement	Hi, Lo
10	156.500	156.500	Intership	Hi, Lo
11	156.550	156.550	Port Operations, Ship Movement	Hi, Lo
12	156.600	156.600	Port Operations, Ship Movement	Hi, Lo
13	156.650	156.650	Intership Navigation, Safety	Hi, Lo
14	156.700	156.700	Port Operations, Ship Movement	Hi, Lo
15 ¹	156.750	156.750	On Board Communications, Intership	Lo Only
16	156.800	156.800	International Distress, Safety	Hi, Lo
17 ¹	156.850	156.850	On Board Communications, Intership	Lo Only
18	156.900	161.500	Public Correspondence (Marine Operator), Port Operations, Ship Movement	Hi, Lo
19	156.950	161.550	Public Correspondence (Marine Operator), Port Operations, Ship Movement	Hi, Lo
20	157.000	161.600	Public Correspondence (Marine Operator), Port Operations, Ship Movement	Hi, Lo
21	157.050	161.650	Public Correspondence (Marine Operator), Port Operations, Ship Movement	Hi, Lo
22	157.100	161.700	Public Correspondence (Marine Operator), Port Operations, Ship Movement	Hi, Lo

Channel Number	Frequency (MHz)		Type of Traffic	TX Power
	TX	RX		
23	157.150	161.750	Public Correspondence (Marine Operator)	Hi, Lo
24	157.200	161.800	Public Correspondence (Marine Operator)	Hi, Lo
25	157.250	161.850	Public Correspondence (Marine Operator)	Hi, Lo
26	157.300	161.900	Public Correspondence (Marine Operator)	Hi, Lo
27	157.350	161.950	Public Correspondence (Marine Operator)	Hi, Lo
28	157.400	162.000	Public Correspondence (Marine Operator)	Hi, Lo
60	156.025	160.625	Public Correspondence (Marine Operator) Port Operations, Ship Movement	Hi, Lo
61	156.075	160.675	Public Correspondence (Marine Operator) Port Operations, Ship Movement	Hi, Lo
62	156.125	160.725	Public Correspondence (Marine Operator) Port Operations, Ship Movement	Hi, Lo
63	156.175	160.775	Public Correspondence (Marine Operator) Port Operations, Ship Movement	Hi, Lo
64	156.225	160.825	Public Correspondence (Marine Operator) Port Operations, Ship Movement	Hi, Lo
65	156.275	160.875	Public Correspondence (Marine Operator) Port Operations, Ship Movement	Hi, Lo
66	156.325	160.925	Public Correspondence (Marine Operator) Port Operations, Ship Movement	Hi, Lo
67	156.375	156.375	Intership, Port Operations	Hi, Lo
68	156.425	156.425	Port Operations, Ship Movement	Hi, Lo
69	156.475	156.475	Intership, Port Operations, Ship Movement	Hi, Lo
71	156.575	156.575	Port Operations, Ship Movement	Hi, Lo
72	156.625	156.625	Intership, Port Operations, Ship Movement	Hi, Lo
73	156.675	156.675	Intership, Port Operations, Ship Movement	Hi, Lo
74	156.725	156.725	Port Operations, Ship Movement	Hi, Lo
77	156.875	156.875	Intership	Hi, Lo
78	156.925	161.525	Public Correspondence, Port Operations	Hi, Lo
79	156.975	161.575	Public Correspondence, Port Operations	Hi, Lo
80	157.025	161.625	Public Correspondence, Port Operations	Hi, Lo
81	157.075	161.675	Public Correspondence, Port Operations	Hi, Lo
82	157.125	161.725	Public Correspondence, Port Operations	Hi, Lo
83	157.175	161.775	Public Correspondence, Port Operations	Hi, Lo
84	157.225	161.825	Public Correspondence, Port Operations	Hi, Lo
85	157.275	161.875	Public Correspondence, Port Operations	Hi, Lo
86	157.325	161.925	Public Correspondence, Port Operations	Hi, Lo

Channel Number	Frequency (MHz)		Type of Traffic	TX Power
	TX	RX		
87A	157.375	157.375	Public Correspondence, Port Operations	Hi, Lo
88A	157.425	157.425	Public Correspondence, Port Operations	Hi, Lo

Notes:

- 1. For channels 15 and 17, output power is fixed at 1 watt only. Transmission at high power is not permitted.*
- 2. Channel 70 is used for Digital Selective Calling (DSC) only and is not available for voice transmissions. Channel 70 does not appear on the display.*

Important Notice

The International frequency mode is not legal for use while operating in U.S. waters. The TX/RX frequencies available in International frequency mode were agreed upon by the attending countries at the 1968 ITU-International Telecommunication Union meeting in Geneva, and are legal for use in International waters only.

Canadian Mode Frequency Table

Canadian Mode				
Channel Number	Frequency (MHz)		Type of Traffic	TX Power
	TX	RX		
01	156.050	160.650	Public Correspondence (Marine Operator)	Hi, Lo
02	156.100	160.700	Public Correspondence (Marine Operator)	Hi, Lo
03	156.150	160.750	Public Correspondence (Marine Operator)	Hi, Lo
04A	156.200	156.200	Pacific Coast: Canadian Coast Guard East Coast: Commercial Fishing Only	Hi, Lo
05A	156.250	156.250	Ship Movement	Hi, Lo
06	156.300	156.300	Intership Safety	Hi, Lo
07A	156.350	156.350	Commercial	Hi, Lo
08	156.400	156.400	Commercial (Intership Safety)	Hi, Lo
09	156.450	156.450	Boater Calling Channel, Commercial and Non-Commercial	Hi, Lo
10	156.500	156.500	Ship Movement, Commercial and Non-Commercial (Intership Safety)	Hi, Lo
11	156.550	156.550	Port Operations, Ship Movement	Hi, Lo
12	156.600	156.600	Port Operations, Ship Movement	Hi, Lo
13 ¹	156.650	156.650	Intership Navigation (Bridge to Bridge)	Lo
14	156.700	156.700	Port Operations, Ship Movement	Hi, Lo
15 ²	156.750	156.750	On Board Communications	Lo Only
16	156.800	156.800	International Distress, Safety, and Calling	Hi, Lo
17 ²	156.850	156.850	On Board Communications	Lo Only
18A	156.900	156.900	Commercial, Towing on Pacific Coast	Hi, Lo
19A	156.950	156.950	Canadian Coast Guard Only	Hi, Lo
20	157.000	161.600	Port Operation with 1 watt max. power	Hi, Lo
21A	157.050	157.050	Canadian Coast Guard Only	Hi, Lo
22A	157.100	157.100	Communication between Canadian Coast Guard and non-Canadian Coast Guard	Hi, Lo
23	157.150	161.750	Public Correspondence on Pacific Coast and Inland Waters of BC and the Yukon	Hi, Lo
24	157.200	161.800	Public Correspondence in all areas	Hi, Lo
25	157.250	161.850	Public Correspondence on Pacific Coast and Lake Winnipeg	Hi, Lo
26	157.300	161.900	Public Correspondence, Safety	Hi, Lo
27	157.350	161.950	Public Correspondence on Pacific Coast, Atlantic Coast, and Great Lakes	Hi, Lo

Channel Number	Frequency (MHz)			TX Power
	TX	RX	Type of Traffic	
28	157.400	162.000	Public Correspondence on Pacific Coast	Hi, Lo
60	156.025	160.625	Public Correspondence	Hi, Lo
61A	156.075	156.075	Pacific Coast: Canadian Coast Guard East Coast: Commercial Fishing Only	Hi, Lo
62A	156.125	156.125	Pacific Coast: Canadian Coast Guard East Coast: Commercial Fishing Only	Hi, Lo
64A	156.225	156.225	East Coast: Commercial Fishing	Hi, Lo
65A	156.275	156.275	Great Lakes: Search & Rescue Antipollution Operations Pacific Coast: Towing St. Lawrence River Area: Port Operations (restricted to 1 watt)	Hi, Lo
66A	156.325	156.325	St. Lawrence River / Great Lakes Areas: Port Operations Only (restricted to 1W)	Hi, Lo
67	156.375	156.375	Search & Rescue, Antipollution Operations East Coast Only: Commercial Fishing	Hi, Lo
68	156.425	156.425	Non-Commercial, Marinas & Yacht Clubs	Hi, Lo
69	156.475	156.475	Commercial and Non-Commercial East Coast Only: Commercial Fishing	Hi, Lo
71	156.575	156.575	Commercial and Non-commercial	Hi, Lo
72	156.625	156.625	Maritime Support Operation	Hi, Lo
73	156.675	156.675	Search & Rescue, Antipollution Operations East Coast Only: Commercial Fishing	Hi, Lo
74	156.725	156.725	Ship Movement	Hi, Lo
77 ²	156.875	156.875	Ship Movement, Intership Safety	Lo Only
78A	156.925	156.925	Commercial	Hi, Lo
79A	156.975	156.975	Commercial	Hi, Lo
80A	157.025	157.025	Commercial	Hi, Lo
81A	157.075	157.075	Canadian Coast Guard Only	Hi, Lo
82A	157.125	157.125	Canadian Coast Guard Only	Hi, Lo
83A	157.175	157.175	Canadian Coast Guard Only	Hi, Lo
84	157.225	161.825	Public Correspondence (Marine Operator)	Hi, Lo
85	157.275	161.875	Public Correspondence (Marine Operator)	Hi, Lo
86	157.325	161.925	Public Correspondence (Marine Operator)	Hi, Lo
87	157.375	161.975	Public Correspondence (Marine Operator)	Hi, Lo
88	157.425	162.025	Public Correspondence (Marine Operator)	Hi, Lo

Important Notice

The Canadian frequency mode is not legal for use while operating in U.S. waters.

Notes:

- 1. For channel 13, output power is fixed at 1 watt (low power) by regulation. In an emergency, you can override to high power by pressing and holding PTT and then pressing the MON/ 1/25 key on the base station. Output power is increased to 25 watts while both keys are pressed. After MON/1/25 is released, power returns to 1 watt.*
- 2. For channels 15, 17, and 77, output power is fixed at 1 watt only. Transmission at high power is not permitted.*
- 3. Channel 70 is used for Digital Selective Calling (DSC) only and is not available for voice transmissions. Channel 70 does not appear on the display.*

US Mode Frequency Table

Channel Number	US MODE			TX Power
	Frequency (MHz)		Type of Traffic	
	TX	RX		
01A	156.050	156.050	Port Operations and Commercial, VTS in selected areas	Hi, Lo
03A	156.150	156.150	US Government and Coast Guard	Hi, Lo
05A	156.250	156.250	Port Operations, VTS in selected areas	Hi, Lo
06	156.300	156.300	Intership Safety	Hi, Lo
07A	156.350	156.350	Commercial	Hi, Lo
08	156.400	156.400	Commercial (Intership only)	Hi, Lo
09	156.450	156.450	Boater Calling, Commercial and non-Commercial	Hi, Lo
10	156.500	156.500	Commercial	Hi, Lo
11	156.550	156.550	Commercial, VTS in selected areas	Hi, Lo
12	156.600	156.600	Port Operations, VTS in selected areas	Hi, Lo
13 ¹	156.650	156.650	Intership Navigational Safety (Bridge to Bridge)	Lo
14	156.700	156.700	Port Operations, VTS in selected areas	Hi, Lo
15 ²	—	156.750	Environmental (Receive only)	—
16	156.800	156.800	International Distress, Safety, and Calling	Hi, Lo
17 ³	156.850	156.850	State Controlled	Lo only
18A	156.900	156.900	Commercial	Hi, Lo
19A	156.950	156.950	Commercial	Hi, Lo
20A	157.000	157.000	Port Operations	Hi, Lo
21A	157.050	157.050	Coast Guard only	Hi, Lo
22A	157.100	157.100	Coast Guard Liason and Maritime Safety Info. Broadcasts announced on CH 16.	Hi, Lo
23A	157.150	157.150	Coast Guard only	Hi, Lo
24	157.200	161.800	Public Correspondence (Marine Operator)	Hi, Lo
25	157.250	161.850	Public Correspondence (Marine Operator)	Hi, Lo
26	157.300	161.900	Public Correspondence (Marine Operator)	Hi, Lo
27	157.350	161.950	Public Correspondence (Marine Operator)	Hi, Lo
28	157.400	162.000	Public Correspondence (Marine Operator)	Hi, Lo
61A	156.075	156.075	US Government and Canadian Coast Guard	Hi, Lo
63A	156.175	156.175	Port Operations and Commercial. VTS in selected areas.	Hi, Lo
64A	156.225	156.225	US Government	Hi, Lo
65A	156.275	156.275	Port Operations	Hi, Lo

Channel Number	Frequency (MHz)		Type of Traffic	TX Power
	TX	RX		
66A	156.325	156.325	Port Operations	Hi, Lo
67 ¹	156.375	156.375	Commercial, Bridge-to-Bridge (Intership)	Lo only
68	156.425	156.425	Non-Commercial	Hi, Lo
69	156.475	156.475	Non-Commercial	Hi, Lo
71	156.575	156.575	Non-Commercial	Hi, Lo
72	156.625	156.625	Non-Commercial (Intership Only)	Hi, Lo
73	156.675	156.675	Port Operations	Hi, Lo
74	156.725	156.725	Port Operations	Hi, Lo
77 ³	156.875	156.875	Port Operations (Intership Only)	Lo only
78A	156.925	156.925	Non-Commercial	Hi, Lo
79A	156.975	156.975	Commercial	Hi, Lo
80A	157.025	157.025	Commercial	Hi, Lo
81A	157.075	157.075	US Government Only: Environmental Protection Operations	Hi, Lo
82A	157.125	157.125	US Government Only	Hi, Lo
83A	157.175	157.175	US Coast Guard Only	Hi, Lo
84	157.225	161.825	Public Correspondence (Marine Operator)	Hi, Lo
85	157.275	161.875	Public Correspondence (Marine Operator)	Hi, Lo
86	157.325	161.925	Public Correspondence (Marine Operator)	Hi, Lo
87	157.375	161.975	Public Correspondence (Marine Operator)	Hi, Lo
88A	157.425	157.425	Commercial (Intership Only)	Hi, Lo

Notes:

1. For channels 13 and 67, output power is fixed at 1 watt (low power) by regulation. In an emergency, you can override to high power by pressing and holding PTT and then pressing the MON/1/25 key on the base station. Output power is increased to 25 watts while both keys are pressed. After MON/1/25 is released, power returns to 1 watt.
2. Channel 15 is receive only. Transmission is not permitted.
3. For channels 17 and 77, output power is fixed at 1 watt only. Transmission at high power is not permitted.
4. Channel 70 is used for Digital Selective Calling (DSC) only and is not available for voice transmissions. Channel 70 does not appear on the display.

Important Notice

Channels 3A, 21A, 23A, 61A, 64A, 81A, 82A, and 83A (shaded) are not for use by the general public in U.S. waters. These frequencies may be used only under authorization by the U.S. Coast Guard or under private land mobile license.

Weather Channels and Frequencies

CH	RX Frequency	Type of Traffic	Transmission Type
1	162.550	Weather	Receive only
2	162.400	Weather	Receive only
3	162.475	Weather	Receive only
4	162.425	Weather	Receive only
5	162.450	Weather	Receive only
6	162.500	Weather	Receive only
7	162.525	Weather	Receive only
8	161.650	Weather	Receive only
9	161.775	Weather	Receive only
0	163.275	Weather	Receive only

Important Notice

The US National Oceanic and Atmospheric Administration (NOAA) broadcasts continuous weather reports and severe weather alerts, as needed. The RAY215 is programmed to receive 10 NOAA weather channels and sound an alarm if a weather alert is received.

Weather operation is available only in US frequency mode and can only be heard in the US and Canada.

Ray215

Document Number: R49013



Raymarine Ltd.
Anchorage Park
Portsmouth, Hampshire
England PO3 5TD
+44 (0)23 9269 3611
+44 (0)23 9269 4642 fax
www.raymarine.com

Raymarine Inc.
22 Cotton Road, Unit D
Nashua, NH 03063-4219
USA
603-881-5200
603-864-4756 fax
www.raymarine.com

